

Water & Sanitary Sewer Rules & Standards



Contents

<u>SECTION 1 – GENERAL REQUIREMENTS.....</u>	<u>5</u>
1.01 OVERVIEW	5
1.02 APPLICATION FOR SERVICE.....	5
1.03 EASEMENTS.....	6
1.04 PERMITS	6
1.05 INSURANCE	7
1.06 MEETINGS AND COORDINATION.....	8
1.07 CONSTRUCTION OBSERVATION	8
1.08 PROJECT COMPLETION DOCUMENTS.....	9
1.09 ABBREVIATIONS AND DEFINITIONS	11
<u>SECTION 2 - EXCAVATION, TRANCH SAFETY AND DUST CONTROL</u>	<u>14</u>
2.01 GENERAL.....	14
2.02 SURFACE REMOVAL (Within Public Right-of-Way).....	14
2.03 TRENCH SAFETY SYSTEM	14
2.04 DUST CONTROL.....	15
2.05 MAGNETIC LOCATOR WIRE	15
<u>SECTION 3 - SURFACE REPLACEMENT AND SITE RESTORATION.....</u>	<u>16</u>
3.01 GENERAL.....	16
3.02 PAVEMENT, CURB AND GUTTER REPLACEMENTS.....	16
3.03 TRAFFIC CONTROL.....	16
3.04 LAWN AND GRASS AREA REPLACEMENT.....	16
3.05 MULCHING.....	17
3.06 STAND OF GRASS.....	17
3.07 SODDING	18
<u>SECTION 4 - CONSTRUCTION OBSERVATION, TESTING AND ACCEPTANCE.....</u>	<u>19</u>
4.01 GENERAL.....	19
4.02 OBSERVATION OF SERVICE CONNECTIONS	19
4.03 GRAVITY SEWER TESTING	19
4.04 LIFT STATION AND FORCE MAIN TESTING.....	25
4.05 CLOSED CIRCUIT TELEVISION INSPECTION	28
4.06 DOMESTIC WATER MAIN DISINFECTION AND TESTING	28
4.07 MANHOLE TESTING AND INSPECTION.....	33

SECTION 5 - SANITARY SEWER SYSTEM	0
5.01 BUILDING SEWERS	0
5.02 DESIGN CRITERIA	0
5.03 MINIMUM SEWER STANDARDS.....	1
5.04 EASEMENTS.....	3
5.05 PROTECTION OF WATER SUPPLIES	4
5.06 UTILITY COORDINATION.....	4
5.07 SANITARY SEWERS CROSSING DRAINAGE WAYS.....	4
5.08 GRAVITY SANITARY SEWERS	5
5.09 SANITARY SEWER FORCE MAINS.....	6
5.10 SANITARY SEWER MANHOLES	9
5.11 BUILDING SEWERS	12
5.12 SEWER INSTALLATION.....	13
5.13 DEWATERING AND CONTROL OF SURFACE WATER.....	14
5.14 TRENCHING	15
5.15 BEDDING	16
5.16 BACKFILL.....	16
5.17 TRENCH BOX PULLING AND SHEETING	17
5.18 MANHOLE INSTALLATION	17
5.19 INSTALLATION OF BUILDING SEWERS (LATERALS).....	18
5.20 BUILDING SEWER CONNECTIONS TO PRESSURE MAINS	18
SECTION 6 - LIFT STATIONS.....	20
6.01 GENERAL REQUIREMENTS.....	20
6.02 PUMPING EQUIPMENT	21
6.03 BASIN AND VALVE PIT.....	23
6.04 CONTROL CENTER.....	Error! Bookmark not defined.
6.05 LEVEL CONTROL/FLOAT SWITCHES.....	30
6.06 REMOTE MONITOR PACKAGE	30
6.07 SITE PROTECTION	30
6.08 OPERATION AND MAINTENANCE MANUALS.....	30
6.09 SPARE PARTS	30
6.10 STATION WARRANTY.....	30
6.11 MISCELLANEOUS DESIGN REQUIREMENTS	30

SECTION 7 - DOMESTIC WATER DISTRIBUTION SYSTEM		32
7.01	GENERAL DESIGN STANDARDS.....	32
7.02	VALVES	32
7.03	HYDRANTS	34
7.04	BLOW-OFF ASSEMBLIES	34
7.05	LINE STOPS	34
7.06	TRACER WIRE	35
7.07	WATER MAIN	35
7.08	SERVICES AND METER PITS.....	38
7.09	BACKFLOW PREVENTION.....	39
7.10	SPECIAL CROSSINGS	39
7.11	INSTALLATION	40
7.12	PIPE BEDDING, HAUNCHING, AND BACKFILL.....	42
7.13	PIPE ASSEMBLY.....	43
7.14	SERVICE LINE INSTALLATION	43
7.15	HYDRANT INSTALLATION.....	44
7.16	FUSION BONDING PROCEDURE FOR HDPE PIPE	45
7.17	VALVE INSTALLATION.....	46
7.18	TESTING AND DISINFECTION TAPS.....	46
7.19	SERVICE TAPS.....	46

SECTION 1 – GENERAL REQUIREMENTS

1.01 OVERVIEW

- A. These design and installation Rules and Standards apply to all sanitary sewer and potable water infrastructure construction that will connect to NineStar Connect’s sanitary sewer and water systems or that will be dedicated to NineStar Connect to own and operate. Incorporate applicable standard details and specifications in this manual into the construction plans. These rules and standards are subject to change at any time without notice.
- B. All sanitary sewer and potable water construction plans shall be prepared by a Professional Engineer licensed in the State of Indiana. All submitted plans shall include the Professional Engineer’s seal and signature and date signed.
- C. Coordinate the location of piping, valves, hydrants, lift stations, manholes and appurtenances with NineStar Connect during the design phase.
- D. The Contractor performing the utility Work shall be licensed, bonded and insured.

1.02 APPLICATION FOR SERVICE

- A. Complete and submit the Subdivision Utility Service Application, including all required signatures, maps, final stamped drawings, specifications, calculations, easement documents, etc. on the Application checklist. Direct any questions, and submit the complete Application package to:

Alan Martin/Jamie Bell
NineStar Connect
2243 East Main Street
Greenfield, IN 46140
317-326-3131

- B. The Application will be reviewed to determine if the Application is approved or needs further information or changes. If further information or changes are required:
 - 1. A review letter from NineStar Connect or their Engineer will be provided to the applicant with comments regarding the deficiencies in the Application.
 - 2. Provide further information or requested changes to the design drawings and specifications.
- C. An approved Application is required prior to sanitary or water infrastructure installation.
 - 1. A final invoice for Application Review Fees will be sent to the applicant upon receipt of a complete and approved submittal.
 - 2. Upon receipt of payment of the Application fees, NineStar Connect will issue the Application approval.
 - 3. NineStar Connect will coordinate a preconstruction meeting with the applicant and specify construction observation requirements for the project.

- D. Prior to NineStar Connect authorizing energizing of service from their system (other than for test purposes), the applicant shall provide the following:
1. Sanitary and potable water system test results
 2. Release of Liens
 3. Maintenance Bond
 4. Transfer of Ownership
 5. Recorded Easements
 6. Record Drawings
 7. Pay all fees due to NineStar Connect for Construction Observation Fees of installed sanitary sewer and potable water infrastructure.

1.03 EASEMENTS

- A. The Owner shall provide easements to NineStar Connect across private property for all sanitary sewer and potable water infrastructure prior to construction.
- B. Easements shall be in accordance with NineStar Connect's requirements and easement format. The easement template can be obtained by calling the phone number in Section 1.02. Easements shall first be approved by NineStar Connect and then recorded and filed with the County. Submit a copy of the final RECORDED easement to NineStar Connect for their records.
- C. Contractor is responsible for accurately staking easements and installing sanitary and potable water infrastructure with the correct alignment within the easement.

1.04 PERMITS

- A. The Owner shall obtain all permits and approvals related to the design and construction of sanitary and water infrastructure. Provide copies of all permits to NineStar Connect prior to the start of construction.
- B. Obtain the proper design and construction approvals from the Utility for sanitary and water infrastructure that will discharge or connect to sanitary and water facilities owned and operated by the Utility.
- C. The construction shall be performed in full accordance with any and all permit requirements. Permits and approvals to be obtained by the Owner may include, but are not limited to, permits from the following:
1. NineStar Connect Utility Construction Permit
 2. NineStar Connect Sewer Lateral Connection Permit
 3. NineStar Connect Water Service Connection Permit
 4. Hancock County
 5. Indiana Department of Environmental Management
 6. Indiana Department of Natural Resources
 7. U.S. Army Corps of Engineers
 8. INDOT
- D. Connection Permits are required for any repair, modification or connection of a building sewer lateral or water service line to the NineStar Connect system. Connection permits will

not be issued for connections to sanitary sewer or water systems not yet dedicated to and accepted by the Utility.

1.05 INSURANCE

- A. The Contractor shall purchase and maintain Worker’s Compensation, Commercial General Liability and Automobile Liability insurance, covering all operations by or on behalf of Contractor, on an occurrence basis.
- B. The Contractor's Certificate of Insurance shall name NineStar Connect. Inc. as additionally insured on a primary, non-contributory basis for Commercial General Liability, Automobile Liability, and Excess/Umbrella Liability. The Certificate of Insurance shall clearly state the insurance coverage required is in effect and has not been decreased by claims, if any, paid by the Insurance Company.
- C. Contractor’s Commercial General Liability insurance shall cover against:
 - 1. claims for damages because of bodily injury, sickness or disease, or death of any person other than Contractor’s employees,
 - 2. claims for damages insured by reasonably available personal injury liability coverage, and
 - 3. claims for damages, other than to the Work itself, because of injury to or destruction of tangible property wherever located, including loss of use resulting therefrom.
- D. Provide a Certificate of Insurance to NineStar Connect establishing that Contractor has obtained and is maintaining the policy and coverage required in this Section 1.06.
- E. The policy shall include the following coverages for not less than the following amounts or greater where required by Laws and Regulations.

1. Workers’ Compensation and Related Coverages	
State and Federal	Statutory
Bodily injury, each accident	\$100,000.00
Bodily injury by disease, each employee	\$100,000.00
Bodily injury/disease aggregate	\$500,000.00
2. Contractor’s Commercial General Liability	
General Aggregate	\$2,000,000.00
Products – Completed Operations Aggregate (Shall be maintained for 3 years after final payment.)	\$2,000,000.00
Each Occurrence (Bodily Injury and Property Damage)	\$1,000,000.00
3. Automobile Liability	
Bodily injury, each person	\$1,000,000.00
Bodily injury, each accident	\$1,000,000.00
Property Damage, each accident	\$1,000,000.00
4. Excess or Umbrella Liability	
Each Occurrence	\$5,000,000.00
General Aggregate	\$5,000,000.00

1.06 MEETINGS AND COORDINATION

- A. The Contractor's superintendent shall schedule a pre-construction conference with NineStar Connect a minimum of 72 hours prior to starting construction of sanitary sewer and potable water infrastructure. Sanitary sewer and water infrastructure materials must be onsite and available for inspection at the time of the pre-construction conference.
- B. NineStar Connect shall be informed of, and will attend, monthly construction progress meetings at their discretion. NineStar Connect shall be informed of, and will attend, the one-year warranty inspection from the "in-service" date of the project with the Contractor.
- C. Coordinate with NineStar Connect for operation of valves, hydrants, and blow off assemblies. Give due notice to the Utility before disturbing, undermining, connecting to, or interfering with their facilities. All temporary support and protection of existing utilities is the responsibility of the Contractor.
- D. If an existing utility is damaged, contact NineStar Connect immediately. Repair all damage in accordance with the directive and to the satisfaction of the Utility. A representative from NineStar Connect must be on-site to observe the repair prior to backfill.
- E. Maintain one set of approved construction plans on the job site at all times.

1.07 CONSTRUCTION OBSERVATION

- A. Observation Scheduling and Coordination
 - 1. Sewer and water facilities that will be connected or dedicated to NineStar Connect's sewer and water systems require observation by the Utility's appointed representative during installation.
 - 2. Provide notice to the Utility at least two (2) weeks prior to the planned commencement of construction to arrange for observation.
 - 3. Observation will occur throughout installation and prior to the backfilling of the utilities. All materials and each part or detail of the Work is subject to observation at all times. Provide access to all parts of the utility Work and furnish information and assistance required to make complete and detailed observations.
 - 4. Once the utility construction starts, the Contractor is responsible for informing and notifying the Utility-assigned representative of the following:
 - a. Daily work schedule including any changes in schedule
 - b. Prior notification (3 days) if work is to be performed on weekends or holidays
 - c. Date tests are to be performed
 - d. Date as-built verification is to be performed
 - 5. During construction, should the Contractor propose to deviate from the approved plans or specifications, submit the proposed revision for review and approval prior to making any field changes. NineStar Connect must approve all materials and any proposed deviations from the construction standards.
 - 6. Perform all required testing under the observation of the Utility-assigned representative. It is the Contractor's responsibility to schedule the testing with the representative. Test results obtained in the absence of the Utility's representative will not be accepted.
 - 7. Notify the Utility in writing when ready for the Final Inspection. NineStar Connect will schedule the Final Inspection.

8. Sanitary sewer and water systems shall not be accepted, nor will service connection permits be issued, until all requirements for observation, testing and project closing documents are complete.

B. Construction Observation Fees

1. Estimated observation fees shall be paid by the Owner prior to issuance of a construction permit and at the following rates.
 - a. Water \$75/EDU
 - b. Sewer \$75/EDU
2. NineStar Connect will notify the Owner of the amount of the estimated cost for observation services that will be rendered by representatives of the Utility. The estimated cost will be based on the number of residential lots (or the number of EDUs for commercial/industrial development) in accordance with approved construction plans.
3. The observation cost is a pre-construction estimate only. The actual observation cost will vary from project to project and may exceed the estimate based upon actual construction circumstances and events. For example, where a pumping station is involved, additional costs for observation during construction and final checkout of the station will be added.
4. Payment of any additional costs for observation services is due prior to the Utility's acceptance of the system.
5. Deviations from approved construction documents or Owner established schedules that create the necessity of additional observation costs, shall be at the Owner's expense.
6. The Owner is responsible for costs associated with any other agency having jurisdiction over the Work.

1.08 PROJECT COMPLETION DOCUMENTS

- A. The documents listed in this section are required to be executed prior to authorization to obtain sewer or water service from NineStar Connect's systems. The forms can be obtained through the contact information provided in Section 1.02.

B. Release of Liens

1. The Contractor shall provide Release of Liens for the sanitary sewer and water facilities to be transferred for ownership to NineStar Connect. Release of Liens shall be provided from the Contractor and all Subcontractors and Suppliers involved in the furnishing of labor, materials or equipment for the sanitary sewer and potable water improvements.

C. Maintenance Bond

1. Provide a Maintenance Bond from a company licensed by the State of Indiana to provide such surety. The Maintenance Bond shall be equal to 25% of the cost of the sanitary and water infrastructure or other amount established by NineStar Connect to provide guarantee against defective materials and workmanship in connection with maintenance of the improvements for which NineStar Connect will be taking ownership.
2. The duration of the Maintenance Bond shall be three (3) years, unless NineStar Connect determines a longer Bond is warranted due to factors such as poor workmanship observed during construction.

D. Recorded Easements

1. Submit a copy of the final RECORDED easement to NineStar Connect for their records per Section 1.03.

E. Transfer or Ownership Agreement

1. The Owner is required to execute the Transfer of Ownership agreement for the sanitary sewer or potable water facilities to be dedicated to NineStar Connect.

F. Record Drawings

1. Provide "as-built" drawings at the completion of sanitary sewer and potable water infrastructure installation. Show all changes made to the design drawings to depict the actual installation. Accurately show the final location of all sanitary laterals and water service lines on the drawings. Submittal and approval of record drawing files is required prior to execution of the Transfer of Ownership document with NineStar Connect.
2. The project Design Engineer shall prepare and submit the following Record Drawings formats via email, online file share, or compact disc to NineStar Connect. Label each file/disk with the project name, property name and date.
 - a. One PDF digital copy
 - b. One shapefile (.shp format) or other Utility-approved file type compatible with NineStar Connect's GIS software
 - c. One AutoCAD DWG file
3. PDFs: All sheets shall have "RECORD DRAWINGS" boldly printed on them with the date, stamp, and signature of the Professional Design Engineer registered in the State of Indiana. Drawings shall clearly differentiate between the original design and changes made to the design during construction. If the Design Engineering firm did not verify the changes that are shown on the Record Drawings, indicate the source of the information (i.e. changes recorded per the Contractor's markups, observer on site, etc.) and disclaim verification of the information by the Design Engineer.

G. Provide GPS data collection of the new sanitary sewers and structures, water mains and appurtenances, including:

1. Horizontal alignment of sanitary and water pipes, with length, size and material type labeled
2. Location of hydrants, water valves, curb stops, meters, service lines, and fittings (bends, tees, etc.)
3. Location of pumping stations, sanitary manholes, structure and pipe invert elevations, top of casting elevations, building laterals and air release valves
4. Building pad elevations
5. Easement locations, type labeled and dimensions
6. Any other sanitary and water facility information requested by Utility

H. GPS requirements

1. Horizontal coordinates shall be recorded based on Indiana State Plane Coordinate System, East Zone
2. Elevations based upon NAVD 1988 datum

3. Tie into section corners in the Indiana State Plane Coordinate System to insure proper orientation.
4. Mark underground fittings and sanitary lateral locations with a lathe if covered during construction to capture with GPS later.

1.09 ABBREVIATIONS AND DEFINITIONS

A. In these Standards, or in any documents or instruments where the Standards govern, when the following terms, abbreviations, or definitions are used, the intent and meaning shall be interpreted as follows.

B. Abbreviations

ASTM	American Society of Testing and Materials
AASHTO	American Association of State Highway and Transportation Officials
AWWA	American Water Works Association
ANSI	American National Standards Institute
ASME	American Society of Mechanical Engineers
ACI	American Concrete Institute
AREA	American Railway Engineers Association
NEMA	National Electric Manufacturers Association
INDOT	Indiana Department of Transportation
OSHA	Federal Occupational Safety and Health Act
WPCF	Water Pollution Control Federation

C. Definitions

1. **ACCEPTANCE:** The formal written acceptance by NineStar Connect of an entire project which has been completed in all respects in accordance with the approved Plans, Specifications and these Standards including any previously approved modifications.

2. **BACKFILL:** Earth and/or other material used to replace material removed from trenches during construction which is above the pipe bedding.
3. **BEDDING:** That portion of the trench backfill which encases the sewer pipe to a minimum depth above and below the bell/barrel of the pipe, as provided in the **BEDDING** section of these Standards, for the purpose of properly supporting the pipe.
4. **BUILDING SEWER (LATERAL):** The conduit for transporting waste discharged from the building to the public sanitary sewer commencing three (3) feet outside the building walls and ending at and exclusive of the wye or tee fitting at the connection to the public sanitary sewer.
5. **CONTRACTOR:** Any Contractor who meets the Utility's requirements to perform the work of installing sewer and water infrastructure under the Utility's jurisdiction.
6. **COUNTY:** The County of Hancock, State of Indiana
7. **EASEMENT:** An area along and adjacent to the public sanitary sewer and water infrastructure which encompass the dedicated sanitary sewer and water infrastructure and is recorded in the name of NineStar Connect, Inc. granting rights within such area to access, maintain and improve the infrastructure.
8. **ENGINEER:** The Engineer for the Utility.
9. **GOVERNING AGENCY/BODIES:** Governing Agency having jurisdiction due to location or type of work being performed. Includes at a minimum NineStar Connect, Hancock County, and applicable State and Federal Agencies.
10. **INFILTRATION/INFLOW:** The total quantity of water from both infiltration and inflow without distinguishing the source.
11. **INSPECTOR/OBSERVER:** A representative of the Utility assigned to inspect/observe any or all portions of the work and materials. The representative has full authority to reject materials and any portion of the Work not supplied and installed in accordance with these Standards and to stop work if the Work is not proceeding in accordance with these Standards.
12. **PROVIDE:** Furnish and install.
13. **PUMPING STATION:** Any arrangement of pumps, valves and controls that lift and/or convey water or wastewater to a higher elevation.
14. **OTHER SPECIFICATIONS AND MATERIALS:** Wherever in these Standards other specifications or regulations are mentioned, it shall be understood that the materials and methods mentioned therewith shall conform to all requirements of the latest revision of the specifications so mentioned.
15. **OWNER:** Any individual, partnership, firm, corporation or other entity who, as property owner, is initiating the work.
16. **PERMITS:** Clearance to perform specific work under specific conditions at specific locations. The Owner or his duly authorized representative shall furnish to the Utility all necessary plans and documents required by the Utility to make application for permits.
17. **PLANS:** Construction plans, including system maps, sewer plans and profiles, cross sections, water mains drawings, utility plans, details, etc., which show location, character, dimensions and details of the Work to be done.
18. **PUBLIC SEWER:** Any sewer constructed, installed, maintained, operated and owned by the Utility.
19. **RECORD DRAWING (AS-BUILTS):** Drawings certified, signed and dated by a Professional Engineer registered in the State of Indiana, indicating that the Record Drawings have been revised to accurately show all as-built construction details of a project according to information gathered or provided.
20. **RIGHT-OF-WAY:** All land or interest therein which by deed, conveyance, agreement, dedication or process of law is reserved for or dedicated to the use of the general public.

21. SEWER: A pipe or conduit for carrying wastewater (sanitary sewer).
22. STANDARD DRAWINGS: The drawings of structures, piping, details or devices commonly used and referred to on the plans and in these Standards.
23. STANDARDS: The Standards for Design and Construction within the NineStar Connect jurisdiction as contained herein and all subsequent additions, deletions or revisions.
24. TEN STATE STANDARDS: *Recommended Standards for Sewage Works* and *Recommended Standards for Water Works*, latest edition, developed by the Committee of the Great Lakes - Upper Mississippi River board of State Engineers.
25. UNIFORM PLUMBING CODE: The Uniform Plumbing code adopted by the International Association of Plumbing and Mechanical Officials, current edition.
26. UTILITY: NineStar Connect, Inc.
27. WORK: All the Work to be done under a permit, in accordance with the approved Plans, Specifications, these Standards and permit conditions.

End of Section 1
General Requirements

SECTION 2 - EXCAVATION, TRANCH SAFETY AND DUST CONTROL

2.01 GENERAL

- A. This section provides for all surface removal, excavation and disposal of surplus material within the public right-of-way, trench safety system and dust control.
- B. Trench safety is a key and vital issue and Owners should take the necessary steps to ensure that the Contractor they employ to construct infrastructure has included trench safety construction techniques and safety systems in the cost proposal.
- C. Backfill all trenches and excavations to the original surface of the ground or such other grades shown on the design plans or as directed. In general, perform backfilling operations as speedily as possible and as soon as concrete, mortar, and other masonry work and pipe joints have sufficient strength to resist the imposed load without damage.

2.02 SURFACE REMOVAL (Within Public Right-of-Way)

- A. For construction of utilities within the Public Right-of-Way, remove the surface materials only to such widths as will permit a trench to be safely excavated, affording sufficient room for efficiency and proper construction. Where sidewalks, driveways, pavement, curbs or gutters are encountered, protect such against fracture or disturbance beyond reasonable working limits. Cut all pavement with an abrasive saw and concrete streets, driveways, walks, alleys, etc. to the nearest joint, and as required by the design plans and the Governing Bodies. Resaw any areas damaged during to provide a clean surface for rehabilitation.
- B. Store excavated topsoil in a designated location as approved by the Governing Bodies. Protect the topsoil to preserve its quality. The topsoil shall be inspected and approved by Utility personnel before being used as backfill for water and sewer infrastructure.

2.03 TRENCH SAFETY SYSTEM

- A. The Contractor and the Owner are responsible for ensuring safe working conditions, and that safety procedures are being followed at the work site. The Contractor is responsible for notifying the Indiana Occupational Safety and Health Administration (IOSHA), Indiana Department of Labor and all other applicable governmental agencies in accordance with their requirements.
- B. The Utility's representative is NOT responsible for policing the Contractor's safety program. If, in the opinion of the representative, an unsafe condition is noted, he will notify the Contractor of this condition and report it to the Owner. If the condition continues to exist the observer shall notify the Owner, document the unsafe condition in writing and/or through a photograph, and leave the job site. The Utility may contact IOSHA and request that they dispatch an inspector immediately.
- C. Regarding Trench Safety Systems, the Contractor shall design, install and maintain a "Trench Safety Program" in strict compliance with OSHA Part 1926 of the Code of Federal Regulations and all other applicable federal, state, and local regulations. The Contractor is responsible to continuously upgrade the Trench Safety Program with changing government regulations.

2.04 DUST CONTROL

- A. Maintain the site and adjoining paved surfaces in a dust free condition. Fugitive dust control is the sole responsibility of the Contractor.

2.05 MAGNETIC LOCATOR WIRE

- A. Install all PVC, HDPE, or non-metallic utilities with a #12 locator wire taped to the top of the pipe.

End of Section 2
Excavation, Trench Safety and Dust Control

SECTION 3 - SURFACE REPLACEMENT AND SITE RESTORATION

3.01 GENERAL

- A. This section pertains to the restoration of areas within the public Right-of-Way and easements where infrastructure is being constructed. Surface restoration within the site being developed is at the direction of the Owner.
- B. Promptly and regularly maintain the site. When the construction is complete, remove all surplus material and rubbish. Repair and replace the disturbed surfaces to as good as or better condition than before the commencement of the work. Repair unsatisfactory trench backfilling and surface and site restoration work.

3.02 PAVEMENT, CURB AND GUTTER REPLACEMENTS

- A. Compact backfill in streets, alleys and other areas that are to be paved using handheld mechanical compaction machines and to the requirements of the Indiana Department of Highways and other governing bodies having jurisdiction. After the trench or excavation has been backfilled, further compact the subgrade for new paving, curbs and gutters by rolling the backfill at subgrade elevation. After examination of the backfill and subgrade compaction operations by the reviewing agencies, place the pavement, curbs and gutters.
- B. Replace all pavements, curbs and gutters with the same materials as that removed and in accordance with the latest Standards of the Indiana Department of Highways, Hancock County, or these standards whichever is more stringent.

3.03 TRAFFIC CONTROL

- A. Maintain vehicular and pedestrian traffic during all paving operations. Comply with the requirements of permits.
- B. Provide flagmen, barricades and warning signs for the safe and expedient movement of traffic through construction zones within the Right-of-Way. Perform such maintenance of traffic in accordance with the principles and standards in the Indiana Department of Transportation, Standard Specifications, latest revision.

3.04 LAWN AND GRASS AREA REPLACEMENT

- A. Restore lawn and grass areas disturbed or damaged during construction to original or better condition. Bring backfills, fills and embankments to a subgrade level six (6) inches below finished grade. After subgrades have settled, place topsoil to a finished depth of at least six (6) inches, rake fine and prepare for seeding.
- B. If the backfill, fill or embankment material is sand, furnish and spread an eight (8)-inch layer of clay over the sand subgrade and thoroughly mix, level and smooth. Place topsoil and spread to a finished depth of at least two (2) inches and rake fine.
- C. On areas to be seeded, uniformly spread a commercial fertilizer 6-12-12 over the topsoil using a mechanical spreader and mix into the soil for a depth of two (2) inches. Apply fertilizer at least forty-eight (48) hours before sowing any seed at the rate of thirty-five (35)

pounds per thousand square feet. Then lightly raked or harrow the area until the surface of the finished grade is smooth, loose and pulverized.

- D. Next, sow the grass seed using a mechanical seeder and lightly rake into the surface or sow with a standard agricultural drill. Thoroughly water the seeded areas with a fine spray in such a manner as not to wash out the seed. Use care in raking to avoid disturbance of the finished grade and seed distribution.
- E. Seed only within the dates extending from August 15 to October 15, and from April 1 to June 1, unless otherwise permitted by the Governing Agencies.
- F. Submit a seed mixture certificate to the Governing Agencies before using. Sow grass seed at the rate of not less than three (3) pounds per thousand square feet and consisting of the following mixture:

35 parts Kentucky Bluegrass
30 parts Perennial Rye
30 parts Kentucky 31 Fescue
5 parts inert matter

- G. When using the hydroseeding method, conduct in accordance with the Indiana Department of Transportation specifications, latest revision.

3.05 MULCHING

- A. Apply adequate mulching material following seeding, fertilizing and cultipacking of the soil.
- B. Mulch shall consist of:
 - 1. Dry straw or hay of good quality and applied at the rate of two and one-half (2-1/2) tons per acre; or
 - 2. Wood cellulose or cane fiber mulch applied at a rate of one thousand (1,000) pounds per acre; or
 - 3. A combination of good quality dry straw or hay free of seeds of competing plants at a rate of two and one-half (2-1/2) tons per acre and wood cellulose or cane fiber mulch at a rate of five hundred (500) pounds per acre; or
 - 4. Manufactured mulch materials such as soil retention blankets, erosion control netting, or others that may be required on special areas of high-water concentration or unstable soils. When these materials are used, follow the manufacturer's recommendation for installation. The seeded area shall be watered, maintained and patched as directed by the Governing Agency until the Contractor's work is completed and accepted.

3.06 STAND OF GRASS

- A. Establish a satisfactory stand of grass that provides full coverage without bare spots. This is not required for areas subject to agricultural activities.
- B. Within one (1) year after work completion, correct any defective work, such as bare spots in grass coverage, erosion, gullies, etc. in a timely manner upon notification.

3.07 SODDING

- A. Sod areas where shown on the plans or as required by the Governing Agencies.
- B. The use of sod shall be in accordance with the Indiana Department of Highway specifications, latest revision. At a minimum, provide sod that is fibrous, well rooted bluegrass, or other approved sod, with the grass cut to a height of not more than three (3) inches. Edges of sod shall be cleanly cut, either by hand or machine, to a uniform thickness of not less than one and one-half (1-1/2) inches, to a uniform width of not less than sixteen (16) inches, and in strips of not less than three (3) feet in length.
- C. Sod shall be free from all primary noxious weeds as defined by the Indiana State Seed Law.
- D. Remediation of soils intended for agricultural use shall include the application of necessary macro and micronutrients, including lime and organic material to return the soil to near pre-construction condition.

End of Section 3
Surface Replacement and Site Restoration

SECTION 4 - CONSTRUCTION OBSERVATION, TESTING AND ACCEPTANCE

4.01 GENERAL

- A. This section describes the minimum requirements and general procedures for the inspection and testing of sanitary sewer and potable water systems to be dedicated to NineStar Connect.
- B. Conduct all tests in the presence of the Utility Representative. Preliminary tests made by the Contractor without being observed by the Utility Representative will not be accepted. Notify the Utility Representative at least 36 hours (not including holidays or weekends) before any Work is to be inspected or tested.
- C. Notify applicable utilities prior to construction to request locating services and verify utility locations.
- D. Repair any section of infrastructure not passing the tests prescribed herein to the satisfaction and approval of the Utility, and then retested and re-inspected at the Owner's expense.
- E. Sections of the system may be tested separately, but any defect which may develop in a section previously tested and accepted shall be promptly corrected and retested at no additional cost to NineStar Connect.
- F. Manholes, water meters, fire hydrants, etc. shall be properly set at final grade. Costs associated with raising or lowering due to grade changes will be at the Owner's expense.
- G. Test all manholes and piping systems in accordance with these standards in addition to any test required by the Indiana Department of Environmental Management (IDEM), State, or Local plumbing codes and building authorities.

4.02 OBSERVATION OF SERVICE CONNECTIONS

- A. Following the installation/repair/modification and prior to the backfilling of the service line, the Contractor/Plumber shall notify the Utility that the service line is ready to be inspected. The Utility will check the installation within twenty-four (24) hours after which the Contractor/Plumber may backfill the trench. Inspections requested on Fridays or on a day proceeding a holiday may not be completed until the next normal business day.
- B. If notification is not provided and the building sewer or water line is backfilled prior to inspection, at the Utility's request the Contractor/Plumber shall be required to re-excavate the trench so that an inspection can be made.
- C. Protection of open trenches and compliance with applicable OSHA Standards is the responsibility of the Contractor/Plumber.

4.03 GRAVITY SEWER TESTING

- A. Flush new piping systems with water to remove any debris prior to testing.

- B. All underground sewer piping for gravity flow shall be subjected to an air test rather than an infiltration or exfiltration test; however, infiltration and exfiltration test methods may be requested during construction. No extra compensation will be allowed if such tests are required.
- C. When leakage occurs in excess of the specified limits, locate and repair defective pipe and joints. Remove, reconstruct, and retest as much of the original Work as necessary to obtain a sewer test within the allowable leakage limits.
- D. The Contractor shall bear the complete cost and supply all equipment necessary to perform the tests required.
- E. Conduct tests under the observation of the Utility's representative. The Contractor is responsible for scheduling testing with the representative.
- F. Infiltration / Exfiltration Test (if required)
 - 1. Construct sanitary sewers and manholes watertight and free from leakage.
 - 2. Infiltration
 - a. When the groundwater level is at or above 4 feet above the top of the sewer, the infiltration test will consist of sealing off a length of sewer and measuring the depth of flow over a measuring weir, or by pumping the infiltrated water into containers for measurement.
 - b. Conduct test for a minimum of 4 hours.
 - c. The rate of infiltration into the sanitary sewer system between any two adjacent manholes or the entire system shall not be in excess of 100 gallons per inch of pipe diameter per mile per day (100 gpd/in/mi.). Repair all visible leaks to the satisfaction of the Utility, even if the infiltration requirements are met.
 - 3. Exfiltration
 - a. When the groundwater level is less than 4 feet above the top of the sewer, the exfiltration test will consist of isolating the particular section and filling with water to a point 4 feet above the groundwater level in the upper manhole and allowing it to stand for at least 4 hours.
 - b. The section shall then be refilled with water up to the original point and after 2 hours measure the drop in the water surface level.
 - c. The rate of exfiltration out of the sanitary sewer system between any two adjacent manholes or the entire system shall not be in excess of 100 gallons per inch or pipe diameter per mile per day (100 gpd/in/min.)
- G. Correct any leakage found during the infiltration test at Contractor's expense. The Utility must approve the method of repair. Grouting of the joint or crack to repair the leakage is not permitted. If the defective portion of the sanitary sewer cannot be located, remove and reconstruct as much of the work as necessary to obtain a system that passes infiltration requirements.
- H. Low Pressure Air Test
 - 1. Test gravity sanitary sewers for infiltration by means of a low-pressure air test as generally described herein. Alternate infiltration tests will only be allowed upon written approval by the Utility.

2. Provide equipment and supplies necessary for the performance of a Low-Pressure Air Test, including but not limited to, mechanical or pneumatic plugs and air control panel.
 - a. Air compressor, air storage tank
 - b. Shut-off valve, pressure regulative valve, pressure relief valve and input pressure gauge. Set the pressure regulator or relief valve no higher than 10 psig to avoid over pressurization.
 - c. Use continuous monitoring pressure gauge having a range of 0 to at least 10 psi. The gauge shall be no less than 4 inches in diameter with minimum divisions of 0.10 psi and an accuracy of + 0.04 psi.
 - d. To reduce the potential for sewer line over-pressurization, use two (2) separate hoses. One hose will connect the control panel to the sealed line for introducing low pressure air. The other will be used for constant monitoring of air pressure buildup in the line.
 - e. If pneumatic plugs are utilized, provide a separate hose to inflate the pneumatic plugs.
3. The ground water level shall be determined by excavation by the Contractor.
4. Air Pressure Adjustment: Calculate the air pressure correction, which must be added to the 3.5 psig normal test starting pressure, by dividing the average vertical height, in feet of groundwater above the invert of the sewer pipe to be tested, by 2.31. The result gives the air pressure correction in pounds per square inch (psi) to be added. The allowable pressure drop of 1.0 psig and the minimum time periods are given in Table 1.
5. Maximum Test Pressure: In no case should the starting test pressure exceed 9.0 psig. If the average vertical height of groundwater above the pipe invert is more than 12.7 feet, the section so submerged may be tested using 9.0 psig as the starting test pressure. The 9.0 psig limit is intended to further ensure workman safety and falls within the range of the pressure monitoring gauges normally used.

I. Low Pressure Air Test Procedure

1. Following are general procedures to be employed in the performance of the test. Submit test data sheets to the Utility.
2. Test the sanitary sewer line in increments between manholes in accordance with ASTM F1417.
3. Plug Installation and Testing
 - a. Take precautions necessary, including blocking of stoppers or plugs to protect the safety of property and personnel.
 - b. After a segment of pipe has been backfilled to final grade, prepared for testing, and the specified waiting period has elapsed, place the plugs securely in the line at the ends of each segment to be tested. The seal at one end should have an orifice through which to pass air into the pipe.
 - c. Seal test all plugs before use. Seal testing may be accomplished by laying one length of pipe on the ground and sealing it at both ends with the plugs to be checked. The sealed pipe should be pressurized to 9.0 psig. The plugs shall hold against this pressure without bracing and without any movement of the plugs out of the pipe. No persons shall be allowed in the direct line of the pipe during plug testing.
 - d. Plug the upstream end of the line first to prevent any upstream water from collecting in the test line. This is particularly important in high groundwater situations.
 - e. When plugs are being placed, visually inspect the pipe adjacent to the manhole to detect any evidence of shear in the pipe due to differential settlement between the

pipe and the manhole. A probable point of leakage is at the junction of the manhole and the pipe. This fault may be covered by the pipe plug, and thus not revealed by the air test.

4. Line Pressurization
 - a. Connect an air supply line that contains an off gas valve and a pressure gauge.
 - b. Slowly introduce low pressure air into the sealed line until the internal air pressure reaches 4.0 psig greater than the average back pressure of any groundwater above the pipe, but not greater than 9.0 psig.
 - c. Pressure Stabilization: After a constant pressure of 3.5 to 4.0 psig (greater than the average groundwater back pressure) is reached, throttle the air supply to maintain that internal pressure for at least 5 minutes. This time permits the temperature of the entering air to equalize with the temperature of the pipe wall.
 - d. Timing Pressure Loss
 - 1) When temperatures have been equalized and the pressure stabilized at 4.0 psig (greater than the average groundwater back pressure), shut off or disconnect the air hose from the control panel to the air supply.
 - 2) Observe the continuous monitoring pressure gauge while the pressure is decreased to no less than 3.5 psig (greater than the average back pressure of any groundwater over the pipe). At a reading of 3.5 psig, or any convenient observed pressure reading between 3.5 psig and 4.0 psig (greater than the average groundwater back pressure), commence timing with a stopwatch or other timing device that is at least 99.8% accurate.
 - 3)
 - 4) A predetermined required time for a specified pressure drop shall be used to determine the lines acceptability. Traditionally, a pressure drop of 1.0 psig has been specified. However, other pressure drop values may be specified, provided that the required holding times are adjusted accordingly. If the specified pressure drop is 0.5 psig rather than the more traditional 1.0 psig, then the required test times for a 1.0 psig pressure drop must be halved. Specifying a 0.5 psig pressure drop is desirable in that it can reduce the time needed to accomplish the air test without sacrificing test integrity. Therefore, the following subsections contain provisions for both the traditional 1.0 psig pressure drop and the more efficient 0.5 psig drop which is given in parentheses.
 - e. Determination of Line Acceptance
 - 1) If the time shown in Table 1, for the designated pipe size and length elapses before the air pressure drops 1.0 psig, the section undergoing test shall have passed and shall be presumed to be free of defects. The test may be discontinued once the prescribed time has elapsed even though the 1.0 psig drop has not occurred.
 - f. Determination of Line Failure
 - 1) If the pressure drops 1.0 psig before the appropriate time shown in Table 1 has elapsed, the air loss rate shall be considered excessive and the section of pipe shall be determined to have failed the test.
5. Test Times
 - a. Test Time Criteria: The Ramseier test time criteria requires that no test section shall be accepted if it loses more than "Q" cubic feet per minute per square foot of internal pipe surface area for any portion containing less than 625 square feet internal pipe surface area. The total leakage from any test section shall not exceed 625 Q cubic feet per minute.

- b. Allowable Air Loss Rate: A "Q" value of 0.0015 cubic feet per minute per square foot shall be utilized to assure quality pipe materials, good workmanship, and tight joints.
- c. Test Time Calculation: All test times shall be calculated using Ramseier's equation:

$$T = (0.085) (D * K)/Q \quad (\text{Equation 4.03-1})$$

Where: T = Shortest time, in seconds, allowed for the air pressure to drop 1.0 psig,

K = 0.000419 DL, but not less than 1.0,

Q = 0.0015 cubic feet/minute/square feet of internal surface,

D = Nominal pipe diameter in inches, and

L = Length of pipe being tested in feet.

- d. For more efficient testing of long test sections and/or sections of larger diameter pipes, a timed pressure drop of 0.5 psig may be used in lieu of the 1.0 psig timed pressure drop. If a 0.5 psig pressure drop is used, the appropriate required test times shall be exactly half as long as it is obtained using Ramseier's equation for "T" cited above.

J. Mandrel Test for Select Pipe

1. A five percent (5%) "GO-NO-GO" Mandrel Deflection Test shall be performed on all HDPE and PVC gravity sanitary sewer pipe.
2. Mandrel test the pipes with a rigid device sized to pass five percent (5%) or less deflection (or deformation) of the base inside diameter of the pipe.
3. Conduct the mandrel test no earlier than thirty (30) days after reaching final trench backfill grade, provided that in the opinion of the Utility sufficient water densification or rainfall has occurred to thoroughly settle the soil throughout the entire trench depth. If densification, in the opinion of the Utility, has not been achieved within the thirty (30) daytime frame, increase the mandrel size to measure a deflection limit of three percent (3%).
4. The mandrel (GO-NO-GO) device shall be cylindrical in shape and constructed with nine (9) or ten (10) evenly spaced arms or prongs. Mandrels with less arms are not allowed. The mandrel diameter dimension "D" shall be equal to the inside diameter of the sanitary sewer. Allowances for pipe wall thickness tolerances or ovality (from heat, shipping, poor production, etc.) shall not be deducted from the "D" dimension but shall be counted as part of the 5% or lesser deflection allowance. Each pipe material/type required to be Mandrel tested shall be tested with a mandrel approved by the pipe manufacturer and meeting the requirements of this Section. The "D" mandrel dimension shall carry a tolerance of + 0.01 inches.
5. Hand-pull the mandrel through all sewer lines. Uncover any section of sewer not passing the mandrel and replaced or repaired the sewer to the Utility's satisfaction and retest.
6. Provide proving rings to check the mandrel. Furnish drawings of mandrels with complete dimensions to the Utility upon request for each diameter and specification of pipe.

K. Sewer Segment Television Inspection

1. Video scope entire selection of pipe after all utilities are installed. Provide video and report to NineStar.
2. Perform closed circuit television (CCTV) inspection to internally examine sewer segments.
3. Record inspections on a digital media storage device compatible with a standard PC. The electronic video file format shall be capable of playing on standard software, such as Windows Media Player and indexed to permit fast forwarding of the videos. If the electronic file format requires special software for viewing, provide this software package to NineStar Connect at no cost. The digital media storage device shall include a narrative noting:
 - a. Date, time of day, and depth of flow
 - b. Sewer segment number “from manhole to manhole”
 - c. Depth of upstream and downstream manholes
 - d. Sewer material and diameter
 - e. Closest street address and street name on which sewer is located
 - f. Direction of camera movement (upstream or downstream)
 - g. Surface above sewer (i.e. paved road, gravel alley, grass field, etc.)
 - h. Locations of service connections into sewer
 - i. Locations of obstructions, structural defects, joint deterioration, leakage or evidence thereof, and other abnormalities with respect to the sewer condition and distance in feed from the upstream manhole centerline.
4. Storage device shall visually display date, pipe section number (manhole number) and distance from the center of upstream manhole to center of downstream manhole to accuracy of ± 2 feet. Where an obstruction is encountered and a reverse set up is required, write and verbally note on the video the distance from which manhole measurements are being made. The case shall display this same information as well as crew ID number. Televising field logs shall legibly show the location of each point of significance in relation to an identified manhole.
5. Points of significance to be documented include, but are not limited to, service connections, visible infiltration, unusual conditions, roots, storm sewer connections, broken pipe, presence of scale and corrosion, mineral deposits, hardened sewer debris, structural failures, and other discernible features.
6. Present on digital video a continuous image of not less than ninety percent (90%) of the internal pipe surface at all times. Maximum acceptable speed of camera through the sewer shall be thirty (30) feet per minute. Lighting system shall be adequate for quality pictures. A reflection in front of the camera may require enhanced lighting.
7. Video recording shall be reviewed by NineStar Connect for focus, lighting, clarity of view and technical quality. Maintain sharp focus, proper lighting, and clear distortion-free viewing during camera operations.
8. Failure to maintain these conditions will result in rejection of the video recording by NineStar Connect. Any video recording not acceptable to the Owner shall be re-televised at no cost to NineStar Connect.
9. If any sewer segment obstruction, such as a protruding building lateral, prohibits the passage of the television camera, attempt reverse set up at the next downstream manhole to inspect the remainder of the sewer segment.
10. Should additional obstruction be encountered after deploying the camera from the opposite end of the sewer segment, and no means are available for moving the camera past the obstruction without damage to the equipment, exclude the section of sewer incapable of full inspection from the scope of Work of this Contract.
11. Should the camera get stuck in the sewer, the Contractor shall be responsible for all costs involved in extracting it. Costs related to difficulties encountered during internal

television inspection are incidental to the Contract and such claims will not be considered.

12. Immediately report to NineStar Connect any sewer segment obstructions that prohibit television camera passage. Reference the location and nature of the obstruction.
13. Contractor shall be responsible for damage to public or private property resulting from his televising activities and shall repair or otherwise make whole such damage at no cost to NineStar Connect.

4.04 LIFT STATION AND FORCE MAIN TESTING

- A. The following section describes the testing that shall be performed on the lift station pumps, piping and force main for acceptance and dedication to the Utility.
- B. Tests for exposed piping shall be made before insulation is placed and prior to concealment within the building construction.
- C. Conduct pressure and leakage tests for buried piping after all jointing operations and backfilling are completed, and concrete reaction blocks and restraints have cured at least 14 days. Piping tested before backfill is in place shall be retested after compacted backfill is placed.
- D. Sections of piping between valves, and other short sections of line may be isolated for testing. If shorter sections are tested, provide test plugs or bulkheads at the ends of the test section. Provide all anchors, braces, and other devices required to withstand the test pressure without imposing any thrust on the pipe line.
- E. The Contractor shall be solely responsible for any damage which may result from the failure of test plugs or supports.
- F. Force Main Testing
 1. Hydrostatic Test
 - a. All sewage force mains shall pass a hydrostatic pressure test as specified.
 - b. Slowly fill the piping system with water and expel air from the pipe. Ensure that all air release valves are installed and open in the section being filled, and that the rate of filling does not exceed the venting capacity of the air release valves.
 - c. After the section of line to be tested has been filled with water, apply the specified test pressure and maintain for a minimum period of 2 hours and for such additional period necessary for the Engineer to complete the observation of the line under test.
 - d. If deflects are noted, make repairs and repeat the test until all parts of the line withstand the test pressure.
 - e. Hydrostatic test pressure: 150 percent of design pressure, but not less than 100 psi
 - f. Test duration: 2 hours
 2. Leakage Test
 - a. All buried piping with slip-type or mechanical joints shall pass a leakage test as specified. No leakage is allowed in exposed piping or buried piping with flanged, threaded, welded or mechanical joints.
 - b. After the hydrostatic test has been completed, subject the line to a leakage test under the same pressure specified for the hydrostatic test.

- c. Maintain the pressure within a maximum variation of 5 percent during the entire leakage test. Do not start leakage measurements until a constant test pressure has been established. Measure the line leakage by means of a water meter installed on the supply side of the pressure pump, or method approved by NineStar Connect.
 - 1) The tested section will not be accepted if it has a leakage rate in excess of that rate determined by the formula:

$$L = 0.000135 ND(P)^{1/2} \text{ in which;}$$

L = Maximum permissible leakage rate, in gallons per hour, throughout the entire length of line being tested

N = Number of gasketed joints (two for each flexible coupling joint) in the line under test

D = Nominal internal diameter (in inches) of the pipe

P = The actual pressure in psig on all joints in the tested portion of the line. Determine this actual pressure by finding the difference between the average elevation of all tested pipe joints and the elevation of the pressure gauge and adding the difference in elevation head to the required pressure.

- 2) Where the leakage rate exceeds the permissible maximum, locate and repair leaking joints to the extent required to reduce the total leakage to the required amount.
- 3) All leaks discovered within 1 year from the date of final acceptance of the Work shall be located, repaired and retested by the Contractor, regardless of the total line leakage rate.

G. Wet Well Leakage Testing

1. Leakage tests shall be made and observed by the Utility's representative in the wet well. The test shall be the exfiltration test as described below:
2. After the wet well has been assembled in place, fill all lifting holes with an approved non-shrinking mortar. Perform the test prior to placing any fill material. If the ground water table has been allowed to rise above the bottom of the wet well, lower the water level for the duration of the test. All pipes and other openings into the wet well shall be suitably plugged and the plugs braced to prevent blow out.
3. Fill the wet well with water. If the excavation has not been backfilled and observation indicates no visible leakage after 1 hour; the wet well may be considered to be satisfactorily water-tight. If the test described above is unsatisfactory or if the wet well excavation has been backfilled, the test shall be continued. A period of time up to 24 hours may be permitted, if the Contractor so wishes, to allow for absorption. At the end of this period, refill the wet well to the top, if necessary; and begin the measuring time of at least 8 hours. At end of the test period, refill the wet well to the top, measuring the volume of water added. This amount shall be extrapolated to a 24-hour rate and the leakage determined on the basis of depth.
4. The leakage for each wet well shall not exceed 1 gallon per vertical foot for a 24-hour period. If the test fails this requirement, but the leakage does not exceed 2 gallons per vertical foot per day, repairs by approved methods may be made as directed by the Utility to bring the leakage within the allowable rate of 1 gallon per foot per day.

Leakage due to a defective section or joint or exceeding the 2 gallons per vertical foot per day maximum shall be cause for rejection of the wet well. It shall be the Contractor's responsibility to uncover the wet well as necessary and to disassemble, reconstruct, or replace it as directed by the Utility. The wet well shall then be retested at the Owner's expense.

5. No adjustment in the leakage allowance will be made for unknown causes such as leaking plugs, absorption, etc.; i.e., it will be assumed that all loss of water during the test is a result of leaks through the joints or through the concrete. Furthermore, the Contractor shall take any steps necessary to assure the Utility's representative that the water table is below the bottom of the wet well throughout the test.

H. Manufacturer's Start-Up

1. Prior to NineStar's final inspection of the lift station equipment, the Contractor shall coordinate start-up activities with the pump manufacturer's representative. The Utility's representative **must** be present at the time of manufacturer's start-up.
2. The manufacturer's representative shall thoroughly test and inspect all components of the system. Any deficiencies in equipment and/or workmanship noted during the manufacturer's start-up shall be remedied by the Contractor prior to final inspection.
3. Upon successful completion of the manufacturer's start-up, the manufacturer shall deliver to the Contractor:
 - a. Three (3) copies of the completed, witnessed report with cover letter certifying that all pumping and electrical equipment has been installed and is operating in accordance with manufacturer's requirement.
 - b. One (1) hard copy and one (1) PDF of Operation and Maintenance Manuals
 - c. One (1) complete set of Spare Parts as specified in these Standards.

I. Final Inspection

1. Deliver two (2) copies of the manufacturer's start-up report at the time of final inspection. Provide the following pump test equipment and materials:
 - a. Water to conduct test
 - b. Amp/voltmeter
 - c. Stopwatch
 - d. Tape or level rod to measure float settings
 - e. Keel to mark float settings on lift station wall
 - f. Calibrated test gauge to measure operating head. The gauge shall be calibrated in feet of water from 0 to 100 feet in one-foot increments
 - g. Manufacturer's pump performance curves

- J. Provide a connection for the test gauge on the blind flanged tee in the valve vault. Equip the stem connection with a plug valve to close the connection after testing is complete. The connection shall be left in place and shall be suitable for use as an air bleed off. At a minimum, pump testing shall include a manual check of all on-off operations, alarm and run lights; determination of pump capacity for each pump and both/all pumps simultaneously; and determination of pump capacity with the force main full. Full force main shall be verified by a pressure gauge.

- K. The pumping test results must meet or exceed the design pumping criteria approved by the Utility to successfully pass the final inspection. Repair or replace any deficiencies noted

during the final inspection to the satisfaction of the Utility and re-inspect/retest prior to final acceptance.

4.05 CLOSED CIRCUIT TELEVISION INSPECTION

- A. When the mandrel test shows areas of deflection failure along the pipe or when air testing fails, perform a closed-circuit television inspection of the sanitary sewer between manholes as specified in this section. Thoroughly clean the sewer before the camera is installed and televising commences.
- B. Provide a camera equipped with remote control devices to adjust the light intensity and a minimum of one thousand (1,000) lineal feet of sewer cable. The camera shall transmit a continuous image to the television monitor as it is being pulled through the pipe. The image shall be clear enough to enable the Utility representative and others viewing the monitor to easily evaluate the interior condition of the pipe. The camera should have a digital display for lineal footage and project number. An audio voice-over shall be made during the inspection identifying any problems encountered.
- C. Provide a flash drive of the entire sewer line and reproduction map indicating the pipe segment identification numbers of all pipe that has been televised. If any pipe or joint is found to be leaking, repair that portion of the pipe to the satisfaction and approval of the Utility.

4.06 DOMESTIC WATER MAIN DISINFECTION AND TESTING

- A. Pressure test potable water lines with the Utility's representative present. Notify the Utility at least 72 hours in advance of testing and provide all equipment necessary for the testing.
- B. Each section of pipe shall pass a pressure and leakage test in accordance with the most recent requirements of AWWA Standard C600 for Ductile Iron Pipe or AWWA C605 for PVC pipe, Section 4.1 - Pressure and Leakage Test.
- C. Prior to testing, thoroughly flush lines at a minimum rate of 3 fps. Flushing shall be accomplished by partially opening and closing valves and hydrants several times under the expected line pressure.
- D. Thrust blocks, if used, shall have been in place for not less than 10 days prior to testing lines.
- E. Test Restrictions
 - 1. Test pressure shall not be less than 1.5 times the working pressure at the lowest point along the test section, or 150 psi, whichever is greater, but shall not exceed the pipe, fitting or thrust-restraint design pressures at any point. Test pressure shall not vary by more than ± 5 psi for the duration of the test. Maintain the pressure during the test period by adding makeup water using a test pump. The hydrostatic test shall be at least 2 hours in duration.
 - a. Valves shall not be operated in either direction at differential pressure exceeding the rated valve working pressure. Use of a test pressure greater than the rated valve pressure can result in trapped test pressure between the gates of a double-disc gate valve. For tests at these pressures, the test setup should include provisions,

independent of the valve, to reduce the line pressure to the rated valve pressure on completion of the test. The valve can then be opened enough to equalize the trapped pressure with the line pressure or opened fully if desired.

- b. Test pressure shall not exceed the rated pressure of the valves when the pressure boundary of the test section included closed, resilient-seated gate valves, or butterfly valves. No test sections shall exceed 5 miles in length without prior approval from the Engineer.

F. Test Procedures

- 1. All newly laid pipe or any newly valved section shall be subjected to a hydrostatic pressure of at least 1.5 times the working pressure at the point of testing. The specified test pressure, which is based on the elevation of the lowest point of the line or section being tested as corrected to the elevation of the test gauge, shall be applied by means of a pump connection to the pipe in a manner satisfactory to the Utility. Allow the system to stabilize at the test pressure before conducting the leakage test.
 - a. Before applying the specified test pressure, completely expel air from the pipe, valves, and hydrants. If permanent air vents are not located at high points, install corporation cocks at such points so that air can be expelled as the line is slowly filled with water. After the air has been expelled, close the corporation and apply the test pressure. At the conclusion of the pressure test, remove the corporation cocks and plug, or leave in place if requested by the Utility. At the end of the test duration, return the line pressure to the original test pressure by adding makeup water.
 - b. Carefully examine all exposed pipe, fittings, valves, hydrants and joints during the test. Repair any damaged components during or after the pressure test at the Contractors' expense. Repeat the test until the results are satisfactory to the Utility.
 - c. Accurately measure the total amount of makeup water added during and at the end of the test duration, or leakage, in gallons by means of a water meter installed on the side of the pressure pump.

G. Allowable Leakage

- 1. Leakage shall be defined as the quantity of water that must be supplied into the newly laid pipe or any valved section to maintain pressure within 5 psi of the specified test pressure after the pipe has been filled with water and the air has been expelled. Leakage shall not be measured by a drop in pressure in a test section over a period of time.
 - a. No pipe installation will be accepted if the leakage is greater than that determined by the following formula:

$$\frac{L}{133,200} = SD\sqrt{P}$$

Where:

L = Allowable leakage, in gallons per hour

S = Length of pipe tested, in feet

D = Nominal diameter of the pipe, in inches

P = Average test pressure during leakage test, in psig

ALLOWABLE LEAKAGE PER 1000 FT. OF PIPELINE*

Nominal Pipe Diameter. In.

Avg. Test Pressure (psi)	3	4	6	8	10	12	14	16	18	20	24	30	36	42	48	54
450	0.48	0.64	0.95	1.27	1.50	1.91	2.23	2.56	2.87	3.18	3.82	4.78	5.73	6.69	7.64	8.60
400	0.45	0.60	0.90	1.20	1.50	1.80	2.10	2.40	2.70	3.00	3.60	4.60	5.41	6.31	7.21	8.11
350	0.42	0.56	0.84	1.12	1.40	1.69	1.97	2.25	2.53	2.81	3.37	4.21	5.06	5.90	6.74	7.58
300	0.30	0.52	0.78	1.04	1.30	1.56	1.82	2.08	2.34	2.50	3.12	3.90	4.68	5.46	6.24	7.02
275	0.37	0.50	0.75	1.00	1.24	1.40	1.74	1.99	2.24	2.40	2.99	3.73	4.48	5.23	5.98	6.72
250	0.36	0.47	0.71	0.95	1.19	1.42	1.56	1.90	2.14	2.37	2.85	3.56	4.27	4.99	5.70	6.41
225	0.34	0.45	0.68	0.90	1.13	1.35	1.58	1.80	2.03	2.25	2.70	3.38	4.05	4.73	5.41	6.03
200	0.32	0.43	0.64	0.85	1.06	1.28	1.48	1.70	1.91	2.12	2.55	3.19	3.82	4.48	5.09	5.73
175	0.30	0.40	0.59	0.80	0.99	1.19	1.39	1.50	1.79	1.98	2.38	2.98	3.68	4.17	4.77	5.36
150	0.28	0.37	0.55	0.74	0.92	1.10	1.29	1.47	1.56	1.84	2.21	2.76	3.31	3.86	4.41	4.97
125	0.25	0.34	0.50	0.87	0.84	1.01	1.18	1.34	1.51	1.68	2.01	2.52	3.02	3.53	4.03	4.53
100	0.23	0.30	0.45	0.50	0.75	0.90	1.05	1.20	1.35	1.60	1.80	2.25	2.70	3.15	3.60	4.05

*If the pipeline under test contains sections of various diameters, the allowable leakage will be the sum of the computed leakage for each size

- b. When testing against closed metal-seated valves, an additional leakage per closed valve of 0.0078 gph/in. of nominal valve size is allowed.
- H. When hydrants are in the test section, the test shall be made against closed hydrant valves.
- I. Acceptance of Testing
 - 1. If test results disclose leakage greater than allowable limits, locate and make approved repairs until the leakage is within the specified allowance. Additional tests performed after the repairs will be at the Contractors expense. All visible leaks are to be repaired, regardless of the amount of leakage.
 - 2. Repair all leaks discovered within the maintenance bond duration and retest the repaired segments to confirm leaks have been stopped.
- J. Disinfection of System
 - 1. After construction and pressure/leakage testing is complete, flush the newly installed system to remove dirt and foreign material. The source of potable water shall be flushed prior to use to ensure that contaminants or debris are not introduced into the new pipes. Thoroughly flush lines at a minimum rate of 3 fps. Flushing shall be accomplished by partially opening and closing valves and hydrants several times under the expected line pressure.
 - 2. Then disinfect the lines in accordance with procedures outlined by the American Water Works Association Standard AWWA C651.
- K. Chlorinating Requirements

1. Supply water to the new system through a temporary connection at a constant, measured rate. In the absence of a meter, the rate may be approximated by methods such as placing a Pitot gauge in the discharge and measuring the time to fill a container of known volume.
2. Direct-feed chlorinators, which operate from the gas pressure in the chlorine cylinder, shall not be used for the application of liquid chlorine. Apply liquid chlorine with a solution feed, vacuum operated chlorinator and booster pump.
3. Hypochlorite solutions may be fed using a powered chemical feed pump designed for feeding chlorine solution.
4. At a point not more than 10 ft. downstream from the beginning of the new main, water entering the new main shall receive a dose of chlorine fed at a constant rate such that the water will have not less than 25 mg/L free chlorine. To assure that the correct concentration is provided, measure units shall be taken at regular intervals in accordance with the procedures described in the current edition of Standard Methods for the Examination of Water or Wastewater, AWWA Manual M12, or by using an appropriate chlorine test.
5. The following table lists the amount of chlorine required for each 100 feet for various diameters of pipe. Solutions of one percent (1%) chlorine may be prepared with sodium hypochlorite or calcium hypochlorite. A solution using calcium hypochlorite requires 1 lb. per 8 gallons of water.

**CHLORINE REQUIRED TO PRODUCE 50 mg/l CONCENTRATION
IN 100 FT. OF PIPE BY DIAMETER**

Pipe Diameter (in.)	100-Percent Chlorine (lb.)	1-Percent Chlorine Solution (gal.)
4	0.026	0.32
6	0.06	0.72
8	0.108	1.30
10	0.17	2.04
12	0.24	2.88
16	0.434	5.2

6. While chlorine is being applied, position valves so that the strong chlorine solution will not flow into water mains in active service. Chlorine application shall not cease until the entire main is filled with heavily chlorinated water. The chlorinated water shall be retained in the main for at least 24 hours. During this time, operate all valves and hydrants in the section being treated to ensure disinfection of all appurtenances. At the end of this period, the treated water in all portions of the main shall have a residual of not less than 10 mg/L free chlorine.

L. Flushing

1. After the applicable testing period, remove heavily chlorinated water to prevent damage to the pipe. Flush the chlorinated water from the main until chlorine measurements show that the concentration in the water leaving the main is greater than 0.5 mg/L but less than 2.0 mg/L.
 - a. Properly dispose of heavily chlorinated water to an approved sanitary sewer as required by Section 02102 and AWWA C651, Appendix C. If no sanitary sewer is

available, apply a reducing agent to the water to be wasted to thoroughly neutralize chlorine residual. The following table shows the amount of neutralizing chemicals required. Where necessary, federal, state and local regulatory agencies should be contacted to determine if there are special provisions for the disposal of heavily chlorinated water.

2. Do not permit flushing water to discharge into existing water mains.

POUNDS OF CHEMICALS REQUIRED TO NEUTRALIZE VARIOUS RESIDUAL CHLORINE CONCENTRATIONS IN 100,000 GALLONS OF WATER*

Residual Chlorine Concentration mg/L	Sulfur Dioxide (SO ₃)	Sodium Biosulfate (NaHSO ₃)	Sodium Sulfite (Na ₂ SO ₃)	Sodium Thiosulfate (Na ₂ S ₂ O ₃ ·5H ₂ O)
1	0.8	1.2	1.4	1.2
2	1.7	2.5	2.9	2.4
10	8.3	12.5	14.6	12.0
50	41.7	62.6	73.3	60.0

*Except for residual chlorine concentration, all amounts are in pounds.

M. Bacteriological Test

1. Satisfactory bacteriological test results approved by the Indiana State Board of Health shall be produced for two (2) successive sets of samples, collected at twenty-four (24) hour intervals, before the new mains are accepted for use.
2. Notify Utility when the system and disinfection is complete, and the water is ready for bacteriological testing. The Utility representative will then collect the sample with the Contractor present. The Utility will submit the sample to an independent certified laboratory for bacteriological analysis at the Contractor's expense.
3. Collect samples from the end of the line and test for bacteriological quality in accordance with Standard Methods for the Examination of Water and Wastewater. At least one set of samples shall be collected from the new main and one from each branch. In case of long mains, samples shall be collected along the length of the line, at reasonable intervals, as well as at its end. Samples for bacteriological analysis shall be collected in sterile bottles treated with sodium thiosulfate. No hose or fire hydrant shall be used in the collection of samples.

N. Re-testing and Disinfection

1. If test results are unsatisfactory, re-flush the lines and repeat the disinfection. Repeat testing as noted above until the testing results are satisfactory and the mains are approved for service.

O. Continuity Test

1. Conduct continuity tests on all tracer wire. Repair or replace all tracer wire found not to be continuous after testing at no cost to NineStar Connect.

MANHOLE TESTING AND INSPECTION

- A. Visually inspect each manhole for evidence of leakage. Repair manholes showing to the satisfaction of the Utility, re-inspected, and re-tested at the Contractors expense.
- B. Manholes will be checked by the Utility after installation and again before the one (1) year warranty period ends. If manholes show signs of leakage, they shall be vacuum tested by an approved company and repaired at the Contractor's expense.
- C. Test all manholes using the Standard Test Method for Concrete Sewer Manholes by the Negative Air pressure (Vacuum) Test.
- D. The equipment required to conduct a vacuum test on manholes includes inflatable pipe plugs, test head, vacuum pump, flexible air hose, and a vacuum gauge.
 - 1. Provide test equipment designed specifically for the purpose of testing manholes and capable of drawing a vacuum of 10 inches of mercury (in-Hg).
 - 2. Manufacturer: P.A. Glazier, Inc., Worcester, Massachusetts, 10002, or as approved by NineStar Connect.
- E. Vacuum Test Method
 - 1. Test precast concrete manhole sections using the vacuum test method to demonstrate the integrity of the installed materials and the construction procedures.
 - 2. This test method is used for testing concrete manhole sections utilizing mortar, mastic, or gasketed joints. The test is intended to be used as a preliminary test to demonstrate the condition of the manhole prior to backfill. The test may also be used to test manholes after backfilling; however, Contractor must correlate the testing with the connector supplier.
 - 3. This test method is the companion to metric Test Method C 1244M; therefore, no SI equivalents are shown in this test method.
- F. Procedure
 - 1. All pipes entering the manhole shall be securely plugged and adequately braced against the inside of the manhole to prevent being drawn out of the manhole.
 - 2. Plug all lift holes and any pipes entering the manhole. A vacuum will then be drawn, and the vacuum drop over a specified time period will be measured and used to determine the acceptability of the manhole.
 - 3. Place the test head at the top of the manhole in accordance with the manufacturer's recommendations.
 - 4. Draw a vacuum of 10 in. of mercury on the manhole. The valve on the vacuum line of the test head will be closed and the vacuum pump shut off. Measure the time it takes for the vacuum to drop to 9 in. of mercury.
 - 5. The manhole shall be considered to pass if the time for the vacuum reading to drop from 10 in. of mercury to 9 in. of mercury meets or exceeds the following values .
 - 6. If the manhole fails the initial test, make necessary repairs using an approved method. Re-test he manhole until a satisfactory test result is obtained.
 - 7. Use or failure of this vacuum test shall not preclude acceptance by appropriate water infiltration or exfiltration testing if approved by the Utility.

End of Section 4
Construction Observation, Testing and Acceptance

SECTION 5 - SANITARY SEWER SYSTEM

5.01 BUILDING SEWERS

- A. The following provisions and requirements pertain to Building Sewers. If any conflict exist between these requirements and other laws and regulations, the most stringent requirement shall apply.
- B. Minimum Elevations for Gravity Connection
 - 1. A sanitary sewer connection permit for a gravity connection shall not be granted to homes or buildings where the lowest elevation to have gravity sanitary services is less than one (1) foot above the top of the manhole casting elevation of either the first upstream or downstream manhole on the sewer to which the connection is to be made. See Detail 5A for minimum elevation for gravity connection.
 - 2. If the first upstream or downstream manhole is at a higher elevation, a grinder lift station must be installed. See Detail 5B for Residential Grinder Station Installation.

5.02 DESIGN CRITERIA

- A. Design and install sanitary sewer facilities in accordance with these Rules and Standards and *Ten States Standards for Sewage Works*.
- B. Design all sanitary sewers to carry the estimated flow from the area ultimately contributing to the respective reach of the sanitary sewer. The required capacity shall be established by the Utility in accordance with its Wastewater System Master Plan. In no instance shall a gravity sewer, other than a building lateral, be less than eight (8) inches in diameter.
- C. The following design standards for gravity sewers within or contributing to the NineStar Connect sanitary sewer collection system have been established.
 - 1. Population Density: Population density shall be in accordance with the actual count or character of proposed development.
 - 2. Average Family: The average family unit is considered to be 3.1 persons per single family home.
 - 3. Design Flow: The design of all sanitary sewer facilities shall be based on projected future area population growth and land development characteristics and figures provided by the Utility, including the servicing of existing contiguous developed areas not currently served by sanitary sewers. The values of Average and Peak Design Flow and Design Population shall be values which include the projected future flows and population. The Utility reserves the right to review and determine the appropriateness/applicability of the estimated flow volumes provided. The following shall be used as a guide:
 - 4. Average Design Flows
 - a. Single Family Residential: The average design flow for single family dwellings shall be one hundred (100) gallons per person per day, or 310 gpd per dwelling.
 - b. Commercial/Industrial/Institutional: The average daily design flow for these facilities shall be based on Bulletin S.E. 13 from the Indiana State Board of Health,

latest edition. Table 5-1 of these Standards itemizes estimated design flows for various non-residential facilities.

1) This Bulletin shall be used as a general guideline in determining average flow volumes anticipated from a proposed development. Based upon information submitted by the Owner, these flow volume guidelines may be modified at the Utility's discretion. The Utility may require sewers of greater capacity for potential growth.

5. Peak Design Flow

a. Single Family Residential: The peak design flow for a single-family development shall be calculated per Ten States Standards as follows:

$$\text{Peak Flow} = (\text{Avg. Flow}) \frac{18 + \square P}{4 + \square P}$$

Where P is equal to the total design population in thousands.

b. Commercial/Industrial/Institutional: The peak design flow from commercial, industrial or institutional developments shall be the calculated average daily flow multiplied by 2.5. Industrial processes with greater peak flows shall be reviewed on a case-by-case base.

c. Infiltration: Sanitary sewer design capacity must include an allowance to carry unavoidable amounts of groundwater infiltration or seepage in addition to the peak sanitary flows. Collector and trunk sewers shall be designed to include an allowance of two hundred (200) gallons per day per inch diameter per mile of pipe.

D. Materials

1. Pipe materials acceptable for use as sanitary sewers and force mains shall be as noted in these standards unless approved otherwise by the Utility.
2. Pipelines subject to exposure to petroleum products shall be ductile iron with nitrile, Buna-N, viton, or other petroleum resistant gasket material designed to protect from the specific contaminant.
3. Wrap ductile iron pipe subject to corrosive soils in a polyethylene encasement.

5.03 MINIMUM SEWER STANDARDS

A. Pipe Diameter: Determine the required diameter of gravity sewers using Manning's formula and a roughness coefficient, "n", of 0.013 or the pipe manufacturer's recommendation, whichever is greater. The minimum pipe diameter for gravity sanitary sewers shall be eight (8) inches.

B. Minimum Slopes and Velocities

1. Design and construct sanitary collector and trunk sewers to provide a minimum velocity when flowing full of two (2) feet per second. The minimum acceptable slopes for the design and construction of sanitary sewers are as follows:

<u>Pipe Size (inches)</u>	<u>Minimum Slope (Feet per 100 Feet, %)</u>
8	0.40
10	0.28
12	0.22
15	0.15
18	0.12
21	0.10
24 and greater	0.08

2. SANITARY SEWERS FOUND TO HAVE LESS THAN THE MINIMUM SLOPE SHALL NOT BE ACCEPTED.

C. Minimum Depth

1. For the protection of the sanitary sewer lines from damage caused by utilities installed after the sanitary sewer has been constructed, the minimum depth to crown of all gravity sanitary sewers shall be 4.0 feet, and the minimum depth to crown of all force main sanitary sewers shall be 5.0 feet.

D. Building Sewers

1. Building sewers shall conform to the latest edition of the Uniform Plumbing Code (UPC), the Indiana Department of Fire Protection and Building Safety, these Rules and Standards and the procedures set forth in appropriate Specifications of ASTM and WPCF Manual of Practice No. 9.
2. Building sewers shall not allow migration of groundwater into the system.
3. The building sewer shall connect to the main sewer at a mainline fitting. Connections to manholes shall only be allowed at upstream terminating manholes unless approved by the Utility. Inside drop connections to manholes are not allowed.
4. Building sewers within the Right-of-Way or easement shall be a minimum of six (6) inches in diameter. Building sewers outside of the right-of-way will be a minimum of four (4) inches in diameter and shall be installed at a slope no less than one-eighth (1/8) inch per foot. Building sewers shall have a wye cleanout located within five (5) feet of the building's exterior wall extended to grade.
5. Cleanouts installed under concrete or asphalt paving shall be made accessible by yard boxes or extended flush with paving with approved materials and shall be adequately protected.
6. Terminate building sewers installed for future connections at the Right-of-Way or easement and plug to ensure 100 percent water tightness. Install a #12 magnetic locator wire with sewer laterals to within three (3) feet of the finished grade for the entire length of the lateral.

E. Manholes

1. In areas where future residential, commercial and/or industrial growth can occur, equip new manholes 15 feet deep or deeper with two (2) precast outside drop connections of a size and at an elevation to be determined by the Utility at the time of design to allow

for future connections. Extend the drops from the base to within 10 feet of the final grade surface elevation.

2. To prevent the energy gradient within manholes from increasing, design the pipe crown elevations continuous where possible.
3. Design manholes to be installed in unpaved grassy areas such that the top of the casting is a minimum of six (6) inches above the finished grade to prevent ponding of water. Provide positive drainage away from the manhole.
4. In areas susceptible to flooding, the Engineer shall identify the flood elevation on the plans and design the elevation of the top of the manhole above the 100-year flood elevation.

F. Tracer Wire

1. Furnish tracer wire for service laterals, from sewer main to building
2. For pipe installed by open excavation or within a casing, provide one strand of solid 12 AWG copper wire for the entire length of pipe.
3. For pipe installed by horizontal directional drilling, provide 2 strands of 12 AWG solid, steel core hard drawn extra high strength copper tracer wire for the entire length of pipe. Supply Copperhead Direct Burial tracer wire.
4. Provide splice kits suitable for underground installation for splices and branch connections. Seal connection with epoxy contained in splice kit and wrap with waterproof tape.

5.04 EASEMENTS

A. Whenever possible, design sanitary sewers within the public Right-of-Way. Should the sewers need to be located outside the public Right-of-Way, sewer easements shall be acquired, dedicated and recorded solely for the benefit of NineStar Connect. Show the easement boundaries on the plans and label as "Sanitary Sewer and Water Easement" in lieu of "Utility Easement."

B. The minimum permanent easement widths to be dedicated to the Utility are as follows:

<u>Depth of Sewer from Finished Grade</u>	<u>Minimum Easement (ft.)</u>
up to 15 feet	20
> 15 feet to 25 feet	25
greater than 25 feet	30

C. Provide a minimum 30 feet by 30 feet easement for all submersible lift stations with wet wells up to 30 feet deep. Easements for lift stations with wet wells greater than 30 feet deep and wet well/dry pit lift stations shall be handled on a case by case basis.

D. The sewer easements shall be exclusively under the discretion and control of NineStar Connect. Ingress and egress shall be available to the Utility's crew at all times. No other utility companies are allowed to use the Utility's easements for installation of their utility lines without the expressed written permission of the Utility.

E. All plan sheets shall clearly identify the sanitary sewer easement and the location of all other proposed utilities. The horizontal and profile plans shall identify all utilities proposed to cross the sanitary sewer easement.

5.05 PROTECTION OF WATER SUPPLIES

- A. There shall be no physical connections between a public or private water supply system and a sanitary sewer or appurtenance which would permit the passage of any polluted water into the potable supply.
- B. Sanitary sewers shall be laid at least ten (10) feet horizontally from any existing or proposed water line. The distance shall be measured edge to edge. In cases where it is not practical to maintain a ten (10) foot separation, the appropriate reviewing agency may allow deviation on a case-by-case basis if supported by data from the design engineer. Such deviation may allow installation of the sewer closer to a water main provided that the water main is in a separate trench or on an undisturbed earth shelf located to one side of the sewer, and at an elevation so the bottom of the water main is at least 18 inches above the top of the sewer. Deviations must be approved by IDEM and also in writing by NineStar Connect.
- C. Where sanitary sewers cross above or below water mains, provide a minimum vertical separation distance of 18 inches between the outside edge of the water main and the outside edge of the sewer pipe. Arrange the pipe crossing such that the sewer pipe joints will be equidistant and as far as possible from the water main joints. Provide adequate structural support to prevent damage to the lower pipe.
- D. If it is not possible to obtain proper horizontal and vertical separation as stipulated herein, encase the sewer pipe or use potable water-grade pipe and pressure test to assure water tightness prior to backfilling.
- E. See Detail 5C for minimum crossover and separation requirements for sewer and water mains.

5.06 UTILITY COORDINATION

- A. Show the location of overhead and underground utility lines and existing sewers on the plans according to the best information available. Submit the plans to the various utilities for their review and verification to the best of their records the locations of their facilities in relation to the route of the proposed sewer.
- B. It is the responsibility of the Owner or his authorized representative to coordinate with and get approvals from the various utilities. Obtain authorization to encroach upon any other utilities' easement prior to dedication of the sanitary sewer system to NineStar Connect.

5.07 SANITARY SEWERS CROSSING DRAINAGE WAYS

- A. Sanitary sewers shall be constructed of ductile iron pipe or shall be encased in a minimum of 6" of concrete wherever the sanitary sewer crosses under a naturally occurring drainageway (i.e. creeks, river, streams, etc.). Wherever applicable, the sanitary sewer crossing the drainageway shall be pressure tested to assure 100% water tightness prior to backfilling. All applicable permits from the Indiana Department of Natural Resources (INDR) and the Army Corp. of Engineers shall be the Owner's responsibility. No construction will be allowed without acquiring the proper permits.

GRAVITY SANITARY SEWERS

A. General

1. NineStar currently allows the use of the following pipe materials meeting or exceeding the minimum specifications set forth herein for the construction of gravity sanitary sewers:
2. Polyvinyl Chloride Pipe (PVC)
3. VITRIFIED CLAY PIPE (VCP) is NOT an approved material for the construction of sanitary sewers.
4. In general, all gravity sanitary sewer pipe shall be the bell and spigot type with elastomeric seal joints and smooth interior walls meeting or exceeding all requirements set forth in the latest ASTM Standard referenced herein.
5. THE UTILITY DOES NOT ALLOW THE USE OF SOLVENT CEMENT JOINT FOR GRAVITY SANITARY SEWERS EIGHT (8) INCHES IN DIAMETER OR LARGER.
6. SADDLE CONNECTIONS ARE NOT ALLOWED FOR NEW CONSTRUCTION.
7. Upon request furnish the Utility with manufacturer's certification stating the pipe supplied meets or exceeds all requirements of the applicable ASTM/ANSI standards and these Standards.

B. Polyvinyl Chloride Pipe (PVC)

1. Provide PVC pipe of integral wall bell and spigot type with elastomeric seal joints and smooth inner walls meeting or exceeding the following requirements:
2. Minimum tensile strength of 34.50 MPa per ASTM D-1784
3. Minimum pipe stiffness of 46 psi when measured at 5% vertical ring deflection and tested in accordance with ASTM D-2412
4. Pipe diameter 15 inches or less which are less than 15 feet
 - a. Conform to ASTM D-3034
 - b. Minimum cell classification of 12454-B or 12454-C
 - c. Minimum wall thickness conforming to SDR-35 Type PSM
5. Pipe diameter 15 inches or less which are 15 feet deep or deeper
 - a. Conform to ASTM D-3034
 - b. Minimum cell classification of 12454-B or 12454-C
 - c. Minimum wall thickness conforming to SDR-26 Type PSM
6. Pipe diameter 15 inches or less which are within 10 feet of a water main or 50 feet of a water well, regardless of depth
 - a. Conform to ASTM D-3034
 - b. Minimum cell classification of 12454-B or 12454-C
 - c. Minimum wall thickness conforming to SDR-21 Type PSM
7. Pipe diameter greater than 15 inches
 - a. Conform to ASTM F-679
 - b. Minimum cell classification of 12454-C
 - c. Minimum wall thickness conforming to T-1 as specified in ASTM F-679
8. Joints
 - a. Provide compression type flexible gasketed joints such that when assembled the gasket inside the bell will be compressed radially on the pipe spigot to form a watertight seal.
 - b. The assembly of joints shall be in accordance with the pipe manufacturer's recommendations and ASTM D-3212.

9. Gaskets
 - a. Provide continuous ring, flexible gaskets made of rubber of special composition having a texture to assure a watertight and permanent seal and being resistant to common ingredients of sewage, industrial wastes and groundwater.
 - b. The gasket shall conform to the requirements of ASTM F-477.
 - c. Provide a product of a manufacturer having at least five (5) years' experience in the manufacture of rubber gaskets for pipe joints.
10. Conduct field-cutting of pipe in a neat, trim manner using a hand or power saw. Bevel the cut end using a file or wheel to produce a smooth bevel of approximately 15 degrees with a minimum depth of one-third the pipe wall thickness.
 - a. Field cut pipe will only be allowed to be installed at manholes, at prefabricated tees and wyes, and at the connection of new sanitary sewer to existing sanitary sewer.
11. Fittings: Provide manufactured fittings made of PVC having a cell classification of 12454-B or 12454-C as defined in ASTM D-1784. Provide fittings equal to or greater than the class of the adjacent main line pipe to which they are joined. Provide joints of the same type as used on the adjoining pipe. Securely attach fabricated branches for wyes and tees to the wall of the pipe in a watertight manner and flush with the inside surface of the pipe.
12. Markings: The date of manufacture, class of pipe, specification designation, size of pipe, name or trademark of manufacturer, and identification of plant/location shall be legibly marked on the outside of each pipe section in accordance with ASTM D-3034.
13. Service laterals: minimum 6-inch diameter PVC of the same class as the adjacent sanitary sewer main, conforming to ASTM D3034.

5.09 SANITARY SEWER FORCE MAINS

A. Materials

1. NineStar Connect allows the use of the following pipe materials, meeting or exceeding the minimum requirements set forth herein, for the construction of sanitary sewer force mains:
 - a. Polyvinyl Chloride (PVC) Pipe
 - b. Ductile Iron Pipe (for wet well, valve vault, and in/out of lift station only)
 - c. High Density Polyethylene (HDPE) Pipe
2. Upon request furnish the Utility with manufacturer's certification stating the pipe supplied meets or exceeds all requirements of the applicable ASTM, AWWA and/or ANSI standard.
3. Each pipe segment shall be clearly marked per the requirement of the respective ASTM, AWWA and/or ANSI Standard.

B. Anchorage

1. Anchor force mains to resist thrusts that develop at bends, angles, tees, etc. in the pipe. Calculate the magnitude of the forces to be resisted and provide the calculations as part of the Engineer's design submittal. Attain the required anchorage by installing restrained pipe joints, concrete thrust blocks or anchor blocks based upon sound engineering practices. Anchorage design at force main fittings shall be based on pipeline pressures of at least 25 percent greater than the maximum pump design shut off head plus a water hammer allowance with an appropriate factor of safety.

C. Air/Release Valve

1. Design sanitary sewer force mains without high points and with the top of the force main below the hydraulic grade line at the minimum pumping rate, so that air release valves are not needed, if possible.
2. If high points in the force main cannot be eliminated, an APCO air release valve or approved equal shall be installed at each significant high point where air could become trapped. Install the air release valve in a manhole structure in accordance with these Standards. Provide provisions for draining the structure. A high point shall be considered significant if it is 2 feet or more above the minimum hydraulic grade line, or, when pumping is intermittent, above the static head grade line.
3. Equip air release valves with an exhaust pipe extending to a downward facing elbow with a corrosion resistant, twenty-four (24) mesh screened opening at an elevation of eighteen (18) inches above the ground.
4. See Detail 5D for Air Release Valve.

D. Polyvinyl Chloride (PVC) Force Main

1. Pipe
 - a. Conform to ASTM D-2241, Standard Specification for Polyvinyl Chloride (PVC) Plastic Pipe (SDR SPR). The material used shall conform to ASTM Specification D-1784, Standard Specification of Rigid Polyvinyl Chloride and Chlorinated Polyvinyl Chloride compounds, class 12454-B (PVC 1120).
 - b. Provide pipe with a minimum pressure class/SDR rating of Class 200/SDR 21.
 - c. Pressure class and standard dimension ratios (SDR) are as follows:

Class 200:	SDR 21
Class 250:	SDR 17
Class 315:	SDR 13.5
 - d. All plastic pipe and couplings shall bear identification markings in accordance with AWWA C-900, which shall include the National Sanitation Foundation (NSF) seal of approval.
 - e. The plain end of each pipe length shall have two (2) rings, one (1) inch apart, painted around the pipe at the proper location to allow field checking of the correct setting depth of the pipe in the bell or coupling.
2. Joints
 - a. Provide bell end or coupling push-on type joints
 - b. The push-on joint and joint components shall meet the requirements of ASTM D-3139, Joint for Plastic Pressure Pipe using Flexible Elastomeric Seals. The joint shall be designed to provide for the thermal expansion and contraction experienced with a total temperature change of seventy-five (75) degrees F in each joint of pipe. Joint assembly shall be in accordance with joint manufacturer's standard practice.
 - c. The lubricant shall have no deteriorating effects on the gasket or the pipe. The lubricant containers shall be labeled with manufacturer's name.
 - d. The gasket shall be a continuous ring of flexible joint rubber of a composition and texture which is resistant to common ingredients of sewage, industrial wastes and groundwater, which will endure permanently under the conditions likely to be imposed by this service.
 - e. The gasket shall conform to the requirements of ASTM F-477 and ANSI Standard A-21.11.
3. Fittings

- a. Provide ductile iron fittings, fitting restraints, and pipe joint restrains as specified herein.
 - 4. Marking: The date of manufacture, class of pipe, specification designation, size of pipe, name or trademark of manufacturer, and identification of plant/location shall be legibly marked on the outside of each pipe section in accordance with ASTM D-3034.
- E. Ductile Iron Fittings, Fitting Restraints, and Pipe Joint Restraints
- 1. Provide mechanical joint ductile iron fittings conforming to AWWA C153 and AWWA C110. Use restrained joints instead of thrust blocking.
- F. Ductile Iron Force Main Pipe
- 1. Pipe diameter 8 inches through 36 inches
 - a. Provide centrifugally cast pipe conforming to ANSI A21.51 and AWWA C-151, latest revision.
 - b. Provide pressure class 350, 300, 250, 200 or 150 depending on site conditions. Pipe class will be reviewed for integrity at plan submittal.
 - c. Minimum pipe length: 18 feet
 - 2. Fittings
 - a. Provide fittings standardized for the type of pipe and joint specified and that comply with ANSI A-21.10, AWWA C-110.
 - 3. Joints
 - a. Provide mechanical joints, slip or flanged joints.
 - b. Mechanical joints and accessories shall conform to AWWA Standard C-111, ANSI A-21.11.
 - 1) Bolts and nuts: corrosion resistant high strength alloy steel
 - c. Slip joints with rubber O-ring gaskets shall comply with AWWA Standard C-111 (ANSI A-21.11).
 - d. Flanged joints shall be manufactured with laying dimensions, facing and flanges detailed in accordance with AWWA Standard C-115 (ANSI A-21.15) Class 125.
 - e. Where indicated on plans, provide restrained joint pipe which is in compliance with AWWA C-111. Joints shall permit horizontal and/or vertical deflection after assembly, yet adequately restrain the joint at the full design pressure.
 - 4. Gaskets
 - a. Provide O-ring gaskets sealing the slip joint made of rubber of special composition having a texture to assure a watertight and permanent seal and being resistant to common ingredients of sewage, industrial wastes and groundwater.
 - b. The gasket shall conform to the requirements of AWWA C-111 (ANSI A-21.11).
 - c. Provide a product of a manufacturer having at least five (5) years' experience in the manufacture of rubber gaskets for pipe joints.
 - 5. Marking: Weights of pipe and fittings shall conform strictly to the requirements of ANSI specifications.
 - a. The class designations for the various classes of pipe and fittings shall be cast onto fittings in raised numerals and cast or stamped on the outside of each joint of pipe.
 - b. Weights shall be plainly and conspicuously painted in white on the outside of each joint of pipe and each fitting after the exterior coating has hardened.

5.10 SANITARY SEWER MANHOLES

- A. Install sanitary sewer manholes at the end of each line segment; at all changes in grade, size, materials and alignment; at all intersections; and at distances not greater than 400 feet for sewers 18 inches or less and 600 feet for sewers greater than 18 inches. Cleanouts shall not be substituted for manholes. Coat manhole extensions with an approved factory applied bitumastic coating.
- B. Provide precast concrete sections with no more than 3 holes cast or drilled in the section for handling.
- C. Provide rapid setting patch material in accordance with ASTM C928 and INDOT Standard Specification Section 901 or precast concrete plugs for filling all holes used for handling.
- D. See Detail 5E for Standard Sanitary Manhole.
- E. Types of Manholes
 - 1. Cast-in-Place Manholes
 - a. The Utility will only allow monolithic cast-in-place manholes for special construction where using precast manholes are not feasible. Should a field constructed monolithic manhole be required, submit shop drawings certified by a registered Professional Engineer showing the proposed concrete mix, steel reinforcement details, pipe connections and manhole dimensions to the Utility for approval.
 - 2. Precast Manholes
 - a. Precast reinforced concrete manholes including bases, risers/barrels, cones and flat slabs shall be constructed of either wet or dry cast Class A concrete meeting or exceeding the requirements of ASTM C-478, latest revision. See details 5E and 5F.
 - b. Provide precast reinforced concrete manholes manufactured, tested and marked in accordance with ASTM C-478, AASHTO M199, INDOT Standard Specification Section 907. The base and the first riser section shall be constructed as one complete precast unit. Provide precast eccentric type cones. Flat top sections require preapproval by NineStar Connect. Provide a 24-inch opening.
 - c. For doghouse manhole base, provide precast concrete base with “doghouse” openings. All lift holes shall be thoroughly wetted and completely filled with non-shrink mortar or epoxy gout then smoothed and covered, both inside and out, with a trowelable grade butyl rubber base backplaster material to ensure water tightness.
 - d. Provide ½-inch diameter flexible butyl rubber joint gaskets conforming to ASTM C-443 and AASHTO M-198 for all manhole section joints. Provide Kent seal or approved equal.
- F. Manholes Bases, Inverts and Flow Channels/Bench Walls
 - 1. Provide manhole bases constructed of Class A concrete having a minimum compressive strength of 4,000 psi.
 - a. 6" minimum base thickness for 48" diameter manholes
 - b. 8" minimum base thickness for larger diameter manholes
 - 2. Sumps are not permitted in manholes.

3. The flow channels within manholes shall be an integral part of the precast base. The channels shall be shaped and formed for a clean transition with proper hydraulics to allow the smooth conveyance of flow through the manhole. The bench wall shall be formed to the crown of the inlet and outlet pipes to form a "U" shaped channel as shown in Details in these Standards. The bench wall shall slope back from the crown at minimum 1/2-inch per foot to the manhole wall.
4. For connections to existing manholes, construct and shape flow channels and bench walls in the existing manhole as if it were a new manhole. Use a concrete mixture with a low cure time and the ability to be troweled to a smooth finish.

G. Adjusting Rings

1. Do not use brick or block to adjust the elevation of the frame and cover.
2. Provide a minimum of one (1) adjusting ring for each manhole for adjustment of the manhole frame and cover to the required elevation.
3. Provide a minimum of 4 inches and maximum of 12 inches total adjustment. Supply precast concrete riser section for adjustment greater than 12 inches in height.
4. Provide a watertight seal between the cone and riser ring, each adjoining riser ring, and riser ring and casting by the use of two (2) rows of 1/2-inch extrudable preformed gasket material. Place the material in keyways and completely fill all cavities.

H. Casting, Frame and Cover

1. Provide frame and cover Neenah R-1712-B-SP, Model 1022 -1AGSMD as manufactured by East Jordan Iron Works, or equal with machined bearing surface and Type F concealed pick hole.
2. Sanitary sewer manhole covers shall have the words "sanitary sewer" cast in the cover in raised letters.

I. Extrudable Preformed Gasket Material

1. Use two (2) 1/2-inch wide nominal size butyl rubber base gasket material, conforming to AASHTO M-198 and Federal Specification SS-S-210A, for adjusting ring grooves; between adjusting ring and cone; between adjusting ring and casting; and in joints of precast manhole sections. The gasket material shall be as manufactured by Hamilton Kent-Seal, RUB'R-NEK L-T-M by K.T. Snyder Company, or an approved equal.
2. Use a compatible primer or solvent as recommended by the manufacturer of the butyl base material to prepare surfaces prior to application of butyl base material.

J. Trowelable Butyl Rubber Backplaster

1. Seal the exterior of the manhole from two (2) inches below the bottom riser ring on the cone section to and covering the base of the casting, including the voids on the outside joints of the riser rings with a trowelable grade butyl rubber base exterior backplaster material, 1/4-inch minimum thickness when dry. All interior risers shall be fitted with an approved chimney seal.

K. Outside Drop Manholes

1. No inside drop manhole connections shall be allowed for new sewer construction. Inside drop connections to existing manholes shall only be allowed upon written approval of the Utility.
2. Where a sanitary sewer or sanitary sewer lateral enters a manhole 24 inches or more above the invert of the outgoing sewer, connect the incoming sewer to the manhole by means of an outside drop connection per Detail 5F. Provide precast outside drop connections. Should a precast connection not be feasible, it may be monolithically poured upon approval of the Utility. Submit detailed drawings for approval for all field fabricated drop connections.
3. The footing for the portion of the manhole under the drop shall be connected to the manhole base. Place a minimum of three (3) ½-inch diameter reinforcing rods as dowels into the manhole base. These rods shall be tied to the reinforcements as specified in ACI Building Code requirements. The rods shall be extended as the vertical part of the drop is constructed. In addition, the drop shall be tied into each joint of precast concrete manhole with a minimum 3/8-inch rod to prevent any separation of the drop from the precast manhole.

L. Manhole Diameters

1. The following are minimum manhole diameters for sanitary sewers entering/exiting a manhole at the following angles:

Pipe Size	Pipes Entering/Exiting at 0-45 degrees	Pipes Entering/Exiting at 45-90 degrees
8"-21"	48"	48"
24"	48"	60"
27"-30"	60"	60"
33"-36"	60"	72"

M. Steps

1. Provide manhole steps of polypropylene coated steel reinforcing or an approved non-corrosive fiberglass material. The copolymer polypropylene shall meet the requirements of ASTM D4101 reinforced with deformed 1/2-inch minimum diameter reinforcing steel conforming to ASTM A615, Grade 60. Provide steps 12 inches on center and not more than 24 inches from the top or invert.

N. Sewer Pipes to Manhole Connections

1. To connect a sanitary sewer to a manhole, use either a flexible boot KOR-N-SEAL 1 or 2, flexible connector, cast-in-place Dura-Seal gasket, "A"-lock gasket or an approved equal. Connections to an existing manhole shall be a flexible boot KOR-N-SEAL or by coring the manhole and using Link Seal. If the flexible boot connection is used, placed in the reinforced concrete manhole base and secured to the pipe by a stainless-steel clamp. Flexible connectors and the cast-in-place inflatable gasket shall conform to ASTM C-923.
2. Where connection is made to an existing manhole, rehabilitate the manhole to the current standards of the Utility. Rehabilitate the flow channel and take prescribed repair measures to reduce infiltration. Provide for a watertight seal between the pipe and

manhole connection. The connector shall be the sole element relied upon to assure a flexible watertight seal of the pipe to the manhole. The rubber for the connector shall comply with ASTM C-923 and be resistant to ozone, weather elements, chemicals, including acids and alkalis, animal and vegetable fats, oils and petroleum products.

3. The stainless-steel elements of the connector shall be totally non-magnetic Series 305 stainless steel. Provide a stainless-steel clamp capable of sustaining applied torque in excess of 80 inch-pounds. Submit details of the proposed connection to the Utility for approval. Connections not approved by the Utility are subject to removal and replacement with an approved adapter.

O. Rejection of Precast Manhole Sections

1. Precast reinforced concrete manholes, risers and tops are subject to rejection for any of the following conditions:
2. Fractures or cracks passing through the shell, except for a single end crack that does not exceed the depth of the joint
3. Defects that indicate imperfect proportioning, mixing and molding
4. Surface defects indicating honeycombed or open texture
5. Damaged ends, where such damage would prevent making a satisfactory joint
6. Infiltration into manhole exceeding allowed limits
7. The internal diameter of the manhole section varying by more than one (1) percent from the nominal diameter
8. Not installed in conformance with these standards
9. Not clearly marked as of date of manufacturer, trade name, size designation part number, and ASTM number
10. Having a deviation more than 1/4" from the straight edge at any point across the top of manhole cone section or riser ring
- 11.
12. Having any visible steel bars along the inside or outside surface of the manhole except for reinforcement stirrups or spacers used to position the cage during manufacture

P. Manhole Coatings

1. Provide all manholes with Madewell 1103 exterior epoxy coal tar coating.
2. Provide interceptor manholes and force main discharge manholes with Madewell Mainstay DS-5 interior epoxy coating in accordance to manufacturer's recommendations.

5.11 BUILDING SEWERS

- A. Building sewers shall be either SDR 35, Schedule 80 or Schedule 40 PVC bell and spigot type pipe conforming to ASTM D2241. Joints shall be flexible gasket push-on compression type assembled and installed in accordance with the manufacturer's recommendations.
- B. Any part of a building sewer that is located within ten (10) feet of a water service pipe shall be constructed of water works grade pressure pipe.
- C. VITRIFIED CLAY PIPE (VCP) is **NOT** permitted for building sewer construction.

SEWER INSTALLATION

- A. Use suitable tools and equipment for the safe and convenient handling and laying of pipe. Take care to prevent pipe coatings or wrappings from being damaged. Carefully examine all pipe and fittings for cracks and other defects. Remove defective pipe from the job site immediately. Pipe or fittings discovered to be cracked, broken or defective after being laid, shall be removed and replaced with sound material. Thoroughly clean all pipe and fittings before installation. All pipe and appurtenances should be kept clean until accepted as completed work.
- B. Line and Grade
1. Furnish and set all line and grade stakes (HUB) and stakes for benchmarks. Set benchmarks in strategic locations of the project in order to facilitate installation of the line and grade stakes for each pipeline. Use a laser to set the grade of the pipeline; constantly check the line and grade of the laser beam and the pipe.
- C. Point of Commencement and Laying of Pipe
1. Commence pipe laying at the lowest point in the proposed sewer line. Lay the pipe with the bell end of bell and spigot pipe or with the receiving groove end of tongue and groove pipe pointing upgrade.
 2. Lay each pipe on an even firm bed as specified so that no uneven strain will come in contact with any part of the pipe. Particular care shall be exercised to prevent the pipes from bearing on the sockets. Hand dig all bell holes for bell and spigot pipe.
 3. Completely shove home all pipe (to the assembly mark) in accordance with manufacturers recommendations. On pipe of the tongue and groove type thirty (30) inches and larger in diameter, pressure must be applied to the center of each pipe as it is laid by a winch and cable or other mechanical means.
 4. All connection fittings shall be sealed with a watertight stopper.
 5. Extend the building wye lateral to the Right-of-Way line and place a #12 magnetic locator wire above the end of the pipe to within three (3) feet of the ground surface.
 6. After joint is made, place sufficient bedding material along each side of the pipe to prevent conditions, that might tend to move the pipe off line or grade.
 7. Temporarily plug installed piping systems at end of each day's Work, or other interruption of progress on a given line. Install plugging in a manner satisfactory to NineStar Connect, and adequate to prevent entry of groundwater, mud, stone, debris, and animals into the pipe or the entrance or insertion of deleterious materials.
 8. Securely attach fabricated branches for wyes and tees to wall of pipe in such a manner as to not restrict or otherwise interfere with flow characteristics of the pipe.
- D. Tracer Wire
1. Install tracer wire on service lines, taped to pipe in 15 to 20-foot intervals. Do not wrap around pipe.
 2. Install tracer wire from sanitary sewer main to cleanout and from cleanout to building.
 3. Install tracer wire access box next to each lift station to protect wire. See Detail 5G.
- E. Construction Bulkheads

1. Before extending a sanitary sewer, provide a watertight bulkhead in the existing sewer immediately downstream of the point of connection. Leave the bulkhead in place until the new sanitary sewer has been cleaned of all accumulated water and debris and accepted by the Utility. During all intermissions in construction of the sanitary sewer pipe, plug the open face of the last pipe laid, cover or bulkhead so as to prevent sand, water, earth or other materials from entering the pipe.
2. Cutting of pipe and special castings shall be done by skilled workmen in such manner as to leave a smooth end at right angles to the axis of the pipe without damage to the pipe casting or cement lining. Cutting torches shall not be used.

F. Laying of Pipe in Cold Weather

1. The Utility reserves the right to order pipe installation discontinued whenever, in its opinion, there is danger of the quality of work being impaired because of cold weather. The Contractor is responsible for heating the pipe and jointing material to prevent freezing of joints. Do not lay pipe on frozen ground. Do not lay flexible or semi-rigid pipe when the air temperature is less than 32 degrees F unless proper precautions per the manufacturer's recommendations are used and the method is approved by the Utility.
2. When pipes with rubber gaskets or resilient-type joints are to be laid in cold weather, sufficiently warm the gasket or joint material to facilitate making a proper joint.

G. Abandoned Sanitary Sewers and Structures

1. Bulkhead sewers to be abandoned with mortar and an 8-inch thick brick wall. Fill sewers and structures which are to be abandoned in place with sand or Cellular Concrete and plug, unless otherwise indicated on Plans. Service shall be maintained in such sewers until the Utility orders bulkheads placed. Timber bulkheads are not allowed.
2. All castings on abandoned sanitary structures are the property of the Utility and shall be salvaged by the Contractor and delivered as directed. Unless otherwise specified, remove all abandoned manholes and other sanitary structures to a depth of three (3) feet below the proposed or established grade or existing street grade, whichever is lower.

5.13 DEWATERING AND CONTROL OF SURFACE WATER

- A. Where groundwater is encountered, secure a dry trench bottom before laying pipe. Provide and operate sufficient sumps, pumps, hose, piping, well points, etc., necessary to depress and maintain the groundwater level below the base of the excavation. If unable to remove the standing water in the trench, over-excavate the proposed bottom grade of the sewer bedding, and place not less than three (3) inches of Class No. 2 crushed stone (Indiana Department of Highway aggregate Classification) in the over-excavated area.
- B. The Contractor and Owner are responsible for complying with dewatering regulations and liable for all lawsuits which may arise as a result of the Contractor's dewatering efforts.
- C. Keep the site free of surface water at all times and install drainage ditches, dikes, pumps, and perform other work necessary to divert or remove rainfall and other accumulated surface water from excavations. The diversion and removal of surface and groundwater shall be performed in a manner which will prevent water from accumulating within the construction area.

- D. UNDER NO CIRCUMSTANCES SHALL SURFACE WATER OR GROUNDWATER BE DISCHARGED TO, DISPOSED OF, OR ALLOWED TO FLOW INTO THE SANITARY SEWER SYSTEM.

5.14 TRENCHING

- A. Excavate the width of the trench at and below the top of the sanitary sewer only as wide as necessary for proper installation and backfilling. The trench width shall be consistent with OSHA safety requirements and the manufacturer's recommendations for the type of pipe. The minimum width of trench for sanitary sewers, and force mains, 42-inches in diameter and less shall be 1.25 times the outside diameter (O.D) plus 12-inches (See Detail 5H, 5I, and 5J).
- B. Include a detailed trench drawing in the design plans and specifications submitted to the Utility for review, approval and issuance of a construction permit. For plastic pipe include the manufacturer's product data indicating the type of trench for the size of pipe and depth of construction.
- C. The design of the sewer pipe and structures is predicated upon the width of trench indicated above. Should these limits be exceeded, the Contractor is responsible for the provision and installation of such remedial measures as may be required by the Engineer and/or the Utility.
- D. Excavate bell holes for bell and spigot pipe and mechanical joint pipe so that the entire barrel of the pipe is resting on the bedding.
- E. The pipe trench shall not be excavated more than one hundred (100) feet in advance of pipe laying.
- F. Whenever pipe trenches are excavated below the designed bedding bottom, fill the over-excavation with mechanically compacted No. 8 (1/4-inch to 3/4-inch) crushed stone or No. 8 fractured face aggregate.
- G. Remove all rock, boulders and stones 6-inches in diameter and larger encountered in trenches. Do not use boulders or rocks in trench backfill. Remove any rock encountered to six (6) inches below the pipe and replace with No. 8 crushed stone or No. 8 fractured face aggregate, compacted.
- H. Place material deposits along open trenches so that no damage will result to the work or adjacent property as a result of rain or other surface wash.
- I. If the bottom of the trench is of undesirable material, an additional six (6) inches of trench bottom shall be excavated and filled with Class 2 crushed stone and compacted using a handheld mechanical tamper. Where the distance to stable ground is excessive, the Engineer shall order in writing, other types of foundation as deemed necessary, subject to the approval of the Utility.

5.15 BEDDING

- A. Bedding material shall be Class II and placed in the trench bottom such that after the pipe has been placed, imbedded to grade and aligned, there remains a 4-inch minimum depth of material below the pipe barrel and a minimum of 3-inches below the bell.
- B. Plastic or Flexible Pipe
 - 1. Place bedding around the sides of the pipe up to the springline (1/2 the Outside Diameter). Shovel slice or otherwise carefully place and "walk" or hand tamp to ensure compaction of the haunch area and complete filling of all voids. Add bedding from the springline to twelve (12) inches above the crown of the pipe in six (6) lifts and "walk" in for compaction. Backfill the remainder of the trench as specified.
 - 2. See Detail 5H for Flexible Pipe Trench for Gravity Sewer.
 - 3. See Detail 5I for Flexible Pipe Trench for Pressure Sewer.
- C. Ductile Iron
 - 1. Place bedding around the sides of the pipe up to the springline (1/2 the Outside Diameter). Shovel slice or otherwise carefully placed and "walk" or hand tamp to ensure compaction of the haunch area and complete filling of all voids. Add bedding from the springline to the top of the pipe, in six (6) lifts and "walk" in for compaction. Backfill the remainder of the trench as specified.
 - 2. See Detail 5J for Ductile Iron Pipe Trench for Pressure Sewer.

5.16 BACKFILL

A. Materials

- 1. The following materials shall be used as backfill.
 - Class II Coarse sands and gravels with maximum particle size forty (40) millimeters (1-1/2 inch), including variously graded sands and gravels containing small percentages of fines, generally granular and non-cohesive, either wet or dry. Soil types GW, GP, SW and SP and INDOT classification for "B" borrow material are included in this class.
- 2. Materials shall be agreed upon prior to construction. No significant deviation from this standard will be permitted without authorization by the Utility.
- 3. The term "Select Fill" shall mean the use of Class II backfill materials as described above.

B. Placement

- 1. Areas Subject to Vehicular Traffic
 - a. In areas under proposed or existing paved roads or under or within five feet of pavement, sidewalks, curbs, gutters or similar structures, use granular backfill material complying with the requirements of the Indiana Department of Highways Standard Specifications, latest edition.
 - b. Place the material in uniform layers not exceeding six (6) inches, loose measurement. Within three (3) feet over the top of the sanitary sewer pipe,

thoroughly and uniformly compacted the backfill material with handheld mechanical tampers. Compact the remaining backfill material with mechanical tampers. Achieve a minimum compaction of 95 percent Standard Proctor Density within the backfill material.

- c. Jetting or flooding of the backfill or other alternative compaction methods and materials shall NOT be used.
2. Areas NOT Subject to Vehicular Traffic
 - a. Backfill areas five (5) feet or more from the paved surfaces with clean material free of rocks, frozen lumps of soil larger than 6 inches, wood, debris or other extraneous material; install and compact as noted above.

C. Flowable Fill

1. Depending upon jurisdiction, flowable mortar may be required to be used to fill trenches for pipe, structures, utility cuts and other work extending under pavement, and to fill cavities beneath slope walls and other locations. Installation, materials, and construction requirements shall be in accordance with INDOT Standards.

5.17 TRENCH BOX PULLING AND SHEETING

- A. Where required by OSHA, sheet and brace open cut trenches in accordance with CFR 1926. Upon completion of the work, remove all temporary forms, shores, and bracing. Fill vacancies or voids left by the sheeting with proper bedding material.
- B. Repair any damage to pavement or other structures due to sheeting, shoring, or bracing.
- C. Cut off sheeting and bracing which is to remain in place at the elevation of 1.5 feet above the top of the sewer pipe unless otherwise directed by the Engineer.

5.18 MANHOLE INSTALLATION

- A. Keep structure excavations free from water during construction.
- B. See Detail 5E for Standard Sanitary Manhole.
- C. Preparation of Base
 1. Fill the bottom of the excavation for the manhole with a minimum of six (6) inches of No. 8 crushed stone mechanically compacted to form a stable base. Where poor or unstable soil conditions exist or over excavation has occurred, use additional No. 2 crushed stone or Class B concrete to form a stable base.
- D. Manhole Coating
 1. Trowel apply Madewell 806 trowelable flexible joint and manhole chimney seal on the joints and butyl tape on the seams.
- E. Placement
 1. Place precast manhole sections properly to provide aligned vertical sides. The completed manhole shall be rigid, true to dimensions and watertight. Tolerance shall

not exceed 2 inches for manholes up to 16 feet in depth plus 1/8" per foot for manholes over 16 feet. Check tolerances with a plumb line.

2. Set top of casting at elevation to prevent surface water infiltration in areas of flooding or ponding.
3. Install precast concrete risers and adjusting rings in such combination that the manhole frame will be at the proper elevation.
4. Structures shall be completely constructed to proper finished grade before curbs, asphalt, or other pavement may be installed.
5. Patching and filling under frames will not be permitted.
6. Install manhole frame to grade and centered.
7. Install steps with minimum 3-inch wall embedment and minimum 4-inch clear distance projection from the wall as measured from the point of embedment.
8. Wrap manhole frames located in pavement in minimum 3/8-inch performed joint filter extending from the top to the bottom of the frame.
9. The joints between manhole sections shall be made with an approved rubber O-ring in accordance with ASTM C-443 and a 1/2-inch diameter non-asphaltic mastic (Kent Seal or equal) conforming to AASHTO M-198 and Federal Specifications SS-521-A.

F. Backfill

1. Prior to backfilling, fill all holes used for handling with rapid setting patch material or with precast concrete plugs secured with Portland cement mortar.
2. Backfilling and compaction around manholes shall comply with the requirements specified for the connecting sewer.

5.19 INSTALLATION OF BUILDING SEWERS (LATERALS)

- A. Install building sewers in accordance with Detail 5K or 5L depending on depth.
- B. Terminate service laterals at a depth of no greater than 5' and no less than 4' at the right-of-way line.
- C. Connection to new sanitary sewer shall only be made at a manufactured fitting. No saddle connection shall be allowed if a manufactured fitting exists based upon as-built plans. Commence the installation of building sewers at the connection to the main sewer and lay with the bell end pointing upgrade.
- D. Bed laterals in accordance with PVC flexible pipe as noted in these standards.
- E. When approved by the Utility, building sewers may connect to a manhole, at an elevation of not more than 24 inches above the base.
- F. For developments with new street curb, stamp the top of curb with an "S" at locations of sanitary sewer laterals.

5.20 BUILDING SEWER CONNECTIONS TO PRESSURE MAINS

- A. Connections to pressure mains may be made upon written approval from the Utility.
- B. Owner is responsible for verifying that the pump is sized adequately to pump against the existing force main head.

C. See Detail 5M for Pressure Connection Lateral Detail.

End of Section 5
Sanitary Sewer System

SECTION 6 - LIFT STATIONS

6.01 GENERAL REQUIREMENTS

- A. This section contains requirements for the design and construction of submersible type lift stations, which are the primary type constructed as part of private development. See Detail 6A and 6B for Typical Duplex Lift Station Detail.
- B. Lift Stations shall meet or exceed all requirements of these standards. Any deviations of dimensions, equipment, controls, etc. from the established standards will be considered only upon the submittal of plans and specifications of the proposed changes to the Utility.
- C. Lift Stations, shall be submersible, and include a minimum of two (2) pumps and motors with a minimum pumping capacity of 100 gpm under site operating conditions, wet basin, separate valve pit, valves, piping, hatches, guide rails, pump removal components, control center, float switches, remote monitor package, interconnecting electrical wiring, incoming power and radio alarm supply, and all other features regularly and normally required as a part of a complete and functional facility. All work shall be in accordance with site requirements, details approved in the Plans, these Standards and the manufacturer's recommendations.
- D. Design Lift Stations to operate on 3-phase power.
 - 1. Provide all the mechanical and electrical equipment as an integral package supplied by the pump manufacturer with local representation to provide undivided responsibility and service.
 - 2. The package shall be equal in construction and performance to Flygt equipment and other specific requirements set forth herein.
- E. Submittals
 - 1. Submit to the Utility for review and approval three (3) sets of shop drawings, detailed specifications, pump warranty and performance characteristics for all of the equipment and fixtures to be furnished and installed. Submit the shop drawings and equipment data with a cover letter or Contractor's stamp of approval, indicating that he has reviewed, checked and approved the data submitted. The Utility will review the submittal and render a decision in writing as to the acceptability of the equipment. Without written Utility approval, the equipment will not be considered accepted.
 - 2. Any exceptions to these Standards or approved Plans shall be submitted to the Utility in writing and such exceptions clearly stated. The exceptions must be approved by the Utility prior to proceeding with the work.
- F. Materials
 - 1. All components of the lift station that are exposed to weather shall be constructed of material that is resistant to corrosion and will not require surface protection throughout the expected life of the lift station. In general, these materials are stainless steel, aluminum, fiberglass reinforced polyester (FRP) and ultraviolet stabilized PVC.
 - 2. Valves and piping coming in contact with sewage or installed in the pump or valve chambers shall be coated with 14 mils of coal tar epoxy.

3. All lift station wet wells shall be provided with Madewell 1103 exterior epoxy coal tar coating and Madewell DS-5 interior epoxy coating.
4. Trowel apply Madewell 806 trowelable flexible joint and manhole chimney seal on joints and butyl tape to seams of wet well.

G. Access Drive

1. Provide an access drive to the Lift Station from the nearest public right-of-way conforming to asphalt drive requirements.

H. Pump Data

1. Submit the following pump information for the Utility's review and approval:
 - a. Pump capacity in gallons per minute
 - b. Total dynamic head (TDH) and operating RPM
 - c. Motor Horsepower
 - d. Motor rpm
 - e. Motor voltage, phase and cycle
 - f. Make and model number
 - g. Provide pump curves

6.02 PUMPING EQUIPMENT

A. Pumps

1. Provide submersible type pumps for handling raw unscreened sewage.
 - a. Pump volute, motor and seal housing: high quality gray cast iron.
 - 1) The pump volute shall be fit with a replaceable bronze wear ring to minimize wear on the impeller and help achieve longer balance operating life.
 - b. Impeller
 - 1) either cast iron or cast bronze of a non-clog design capable of handling a minimum three (3) inch sphere solids, fibrous material, heavy sludge, and other matter found in normal sewage applications.
 - 2) pump out vanes on the back shroud of the impeller to keep pumped material away from the seal area and increase operating life.
 - 3) either slip fit or taper fit with key to securely lock the impeller of the driving shaft.
 - c. Fasteners: stainless steel.
2. At least one (1) pump should be equipped with a mix-flush valve similar to Flygt to minimize grease buildup. As an alternative, station should be equipped with a separate mixing pump sequenced to mix when the discharge pumps are turned on, or periodically in order to maintain a homogeneous solution.
3. Stations with pumps greater than 10 HP shall be furnished with variable frequency drives (VFD) to reduce system hydraulic surges.

B. Seals

1. All mating surfaces where watertight sealing is required shall be machined and fitted with nitrile rubber O-rings. Sealing shall be accomplished when metal-to-metal contact is made, resulting in controlled compression of the rubber O-rings without requirement of a specific torque limit.

2. The pump shall be provided with a mechanical rotating shaft seal system running in an oil reservoir having separate, constantly lubricated lapped seal faces. The lower seal unit between the pump and oil chamber shall consist of one (1) stationary seat and one (1) rotating ring held in place by its own spring.
3. The lower seal shall be removable without disassembling the seal chamber.
4. The upper seal between the motor and the seal chamber shall be of the same design with its own separate spring system.
5. The seals shall require neither maintenance nor adjustment and shall be easily inspected and replaceable. Shaft seals with conventional double seal utilizing a single spring between the two (2) seals and requiring a pressure differential to offset external pressure shall not be considered acceptable nor equal to the dual independent seal system specified.
6. The shaft sealing system shall be capable of operating submerged to pressures equivalent to two hundred (200) feet.
7. No seal damage shall result from operating the pump unit out of its liquid environment.
8. The seal system shall not rely upon the pumped media for lubrication.
9. The seal chamber shall also be equipped with a seal failure sensor probe which will sense water intrusion through the lower seal. This sensor is to be connected to an alarm in the control panel to indicate lower seal failure.

C. Housing

1. The stator winding, rotor and bearings are to be mounted in a sealed submersible type housing.
 - a. Insulation utilized in the stator windings shall be Class F with maximum temperature capability of 155 degrees Celsius.
 - b. Motor housing shall be filled with a high dielectric oil to give superior heat transfer and allow the bearing to run in a clean, well lubricated environment or the housing shall be air filled with grease lubricated bearing.
 - c. The pump and motor are to be specifically designed so that they may be operated partially or completely submerge in the liquid being pumped. The pump should not require cooling water jackets.
 - d. Stator shall be securely held in place with removable end ring and threaded fasteners so that it may be easily removed in the field without use of heat or press.
2. Shaft shall be of stainless steel and supported by ball bearings. Motor shall be provided with heat sensing units attached to the motor windings which shall be connected to the control panel to shut down pump if overheating occurs.

D. Cable

1. Pump motor cable and heat sensor/seal failure sensor cable shall be suitable for submersible pump applications and this shall be indicated by a code or legend permanently embossed on the cable. Cable sizing shall conform to NEC specifications for pump motors and shall be of adequate size to allow motor voltage conversion without replacing the cable. Provide cable of the proper length to eliminate need for splices or junction boxes between pump and "control center".
2. The cable shall enter the motor through a cord cap assembly which is double sealed allowing disassembly and disconnect of the wires and the motor and still not damage the sealed characteristics of the motor housing. Each individual conductor shall be color coded in accordance with generally accepted industry standards. The color coding shall designate the application of the conductor.

E. Mounting Base

1. The pump mounting base shall include adjustable guide rail supports and a discharge connection with a 125-pound standard flange. The base and the discharge piping shall be permanently mounted in place. The base plates shall be anchored in place utilizing epoxy type anchors with stainless steel studs and nuts as manufactured by HILTI Fasteners, Inc. or equal.

F. Rail System

1. Provide a rail system for easy removal of the pump and motor assembly for inspection and service. The system shall not require a man to enter the wet well to remove the pump and motor assembly. Provide two (2) guiderails, T-bar or other suitable guide system for each pump. The guide rails shall be positioned and supported by the pump mounting base. The guide rails shall be aligned vertically and supported at the top by attachment to the access hatch frame. One (1) intermediate guide rail support is required for each nine (9) feet of guide rail length for FRP I-Beam rail.
2. The pumps shall be equipped with sliding brackets or rail guides attached to each pump. Provide a stainless-steel lifting chain or manufacturer's pump removal system (similar to the Flygt Lift) of adequate length for the basin depth for each pump. Each pump shall be equipped with a permanent, stationary lifting handle with a minimum clearance of 12 inches between the top of pump and bottom of handle.
3. The rails and the rail guides shall function to allow the complete weight of the pumping unit to be lifted on dead center without binding and stressing the pump housing. The rail system shall function to automatically align the pumping unit to the discharge connection by a simple downward movement of the pump. No twisting or angle approach will be considered acceptable.

G. Warranty

1. Pump warranty shall be provided by the pump manufacturer and shall warrant the units being supplied against defects in workmanship and materials for a period of five (5) years under normal use, operation and service. The warranty shall be in printed form and apply to all similar units. A copy of the warranty statement shall be submitted with the approval drawings.

6.03 BASIN AND VALVE PIT

A. Concrete Materials

1. The basin, valve pit flat tops and base slabs are to be constructed of precast reinforced concrete meeting the requirements of ASTM C-478. Cast-in-place monolithic structures may be substituted with the prior written approval of the Utility. Minimum valve vault and wet well diameter shall be 6'-0". The actual arrangement of the structures are to be as shown in the approved Plans. Provide the wet well basin top with a four (4) inch PVC vent having a downward pointing inlet and screen over the inlet opening. General layouts are given in Details 6A and 6B of these Standards.
2. All joints between precast sections shall be made with an approved rubber O-Ring in accordance with ASTM C-443 and a ½-inch diameter non-asphaltic mastic conforming to AASHTO M-198 and Federal Specification SS-521-A. In addition, the outside wall below grade is to be coated with bituminous waterproofing material. The top and bottom

of the chambers shall be precast or may be poured in place concrete if approved by the Utility.

3. The basin and the valve pit chamber shall be enclosed at grade level with a reinforced concrete pad rectangular in shape and extending a minimum of 1'-0" from the chambers outside dimension.
4. The inside of the wet well shall be coated or impregnated with a material to discourage grease buildup and/or decalcification by Hydrogen Sulfide.

B. Fiberglass Wet Well

1. As an alternate, a fiberglass wet well may be installed. The basin shall be manufactured using the hand lay-up, chopped spray technique and filament wound methods for vertical underground fiberglass basins. Other methods of manufacturing shall not be acceptable. The minimum diameter shall be 6'-0", except for individual residential units which shall be a minimum of 24" in diameter.
2. Resin
 - a. The resin used shall be of a commercial grade and shall be evaluated as a laminate by test or determined by previous service to be acceptable for the environment. The resins used may contain the minimum amount of fillers or additives required to improve handling properties. Up to 5% by weight of thixotropic agent which will not interfere with visual inspection may be added to the resin for viscosity control.
3. Reinforcing
 - a. The reinforcing material shall be a commercial grade of glass fiber having a coupling agent which will provide a suitable bond between the glass reinforcement and the resin.
4. Laminate
 - a. The laminate shall consist of an inner surface, an interior layer, and a filament-wound structural exterior layer of laminate body.
 - b. The inner surface shall be free of cracks and crazing with a smooth finish and with an average of not over two pits per square foot, providing the pits are less than 1/8" in diameter with not over 1/32" deep and are covered with sufficient resin to avoid exposure of inner surface fabric. Some waviness shall be permissible as long as the surface is smooth and free of pits. Between 0.100 and 0.020 inches of resin-rich surface shall be provided.
 - c. Minimum of 0.100 inch of the laminate next to the inner surface shall be reinforced with 30% by weight of chopped-strand fiber having fiber lengths from 0.5 to 2.0 inches.
 - d. Subsequent reinforcement shall be continuous-strand woven fiberglass. The thickness of the filament-wound portion of the tank shell shall vary with the tank height to provide the aggregate strength necessary to meet the tensile and flexural requirements. If additional longitudinal strength is required, the use of other reinforcement, such as woven fabric, chopped-strand mat, or chopped strands shall be interspersed in the winding to provide additional strength. Glass content of this filament-wound structural layer shall be 50 to 80% by weight. Surfaces shall be relatively smooth with no exposed fibers or sharp projections. Hand work finish shall be performed to prevent fiber exposure. The finished laminate shall be as free as commercially practicable from visual defects such as foreign inclusions, dry spots, air bubbles, pinhole, pimples, and delamination.
5. Tank

- a. The tank wall must be designed to withstand wall collapse based on the assumption of hydrostatic type loading by backfill with a density of 120 LB/ CF. The tank wall laminate must be constructed to withstand or exceed two times the assumed loading for any depth of basin.
 - b. For the tank bottom, subsequent reinforcement shall be of 1.5 oz/ SQ FT chopped strand fiber or woven roving to a thickness to withstand applicable hydrostatic uplift pressure, with a safety factor of 2. In saturated conditions, the center deflection of any empty tank bottom shall be less than 3/8" (elastic deflection) and will not interfere with bottom pump mounting requirements nor rail system.
 - c. The tank bottom shall extend past the tank walls so that the O.D. is approximately 4" larger in diameter than the O.D. of the sidewalls. This larger diameter shall serve as an anti-flotation flange. Contractor shall place the tank on a concrete pad and either fill with grout covering the anti-flotation flange or secure with steel clips catching the anti-flotation flange. Anti-flotation flange shall not require bolt holes to secure the tank to the concrete pad.
6. Joint Overlays
- a. The width of the first layer of joint overlay shall be 3" minimum. Successive layers shall uniformly increase in width to form a smooth contour laminate that is centered on the joint +/- 1/2". A highly filled resin paste may be placed in the crevices between joined pieces leaving a smooth surface for lay-up. The cured resin surface of the parts to be joined shall be roughened to expose glass fiber. This roughened area shall extend beyond the lay-up areas so that no reinforcement is applied to an unprepared surface. Surfaces shall be clean and dry before lay-up. The entire roughened area shall be coated with resin after joint overlay is made.
 - b. Tank shall include NPT discharge fittings. A 4-inch neoprene influent grommet shall be provided for mounting in the field.
 - c. The top flange and cover O.D. shall assure a tight fit and afford ease of access. Non-corroding stainless steel heli-coils shall be inserted in all bolt holes of the top flange and shall be positively locked with threads and resin to prevent stripping. A 10-hole pattern shall accommodate the mounting of a one-piece or split steel cover.
 - d. The cover shall be of steel construction with an O.D. equal to the O.D. of the top flange on the basin. The cover shall be secured by stainless steel bolts and coated with a 3-4 mil thick rust-inhibiting paint.

C. Access Hatch

1. The pump supplier shall provide aluminum door access hatch frame and door assemblies to be installed in the concrete basin top. The door assemblies shall provide access for removal of the pumps and shall support the guide rails. The doors shall be provided with lifting handle, safety latch to hold door in the open position and a hasp suitable for padlock. The doors shall have a nonskid finish and be designed for light, medium or heavy duty, depending on the location of the pumping station.
2. An aluminum single door access hatch frame and door assembly similar to the one described above shall be provided for use as entry to the valve pit. Minimum opening for the valve box entry shall be thirty-six (36) inch by thirty-six (36) inch.
3. Single doors or the first opening door of dual-door assemblies shall open towards the control panel to provide a physical barrier between the control panel and the wet well.

D. Check Valve

1. A swing check valve with external swing arm and an eccentric plug valve shall be installed in the valve pit in each pump's discharge piping. A minimum clearance of twelve (12) inches shall be allowed from the bottom of the valves to invert of the pit. A drainpipe and check valve or gate valve shall be installed to drain the valve pit back to the wet basin, but not allow the wet basin liquid to enter the valve pit. In addition, emergency connections for Utility-operated stand-by pumps will be required.

6.04 PUMP CONTROL PANEL

A. Provide the following items, components and appurtenances for the pump control panel.

B. Enclosure

1. NEMA 4X stainless steel enclosure
2. Suitable for the specified horsepower and voltage for the pumping equipment
3. Outside panel door: hinged dead front with provisions for padlock
4. Inside panel: separate hinged panel to protect all electrical components.
5. H-O-A switches, run lights, circuit breakers, etc. shall be mounted such that only the faces protrude through the inside swing panel and no wiring is connected to the back side of the inside swing panel.
6. The pump control panel shall be assembled, tested and listed by a panel shop meeting U.L. Standard 698A for industrial control panels related to hazardous (classified) locations.

C. Disconnect Switch, Transfer Switch

1. Single main fusible or breaker disconnect switch of adequate size to provide power for the control center and its related components.
2. Disconnect switch enclosure: NEMA 4X stainless steel with an external operation handle capable of being locked in the ON position.
3. Transfer switch for generator connection

D. Circuit Breakers, Starters, Relays

1. Circuit breaker and magnetic starter with three (3) leg overload protection and manual reset for each pump.
2. Starters with auxiliary contacts to operate both pumps on override condition.
3. Separate circuit breaker for power to the control circuit.
4. Extra circuit breaker of adequate size to provide 120-volt, single-phase power for the remote monitor panel plus a 20 amp for a receptacle.
5. Control voltage transformer to reduce supply voltage to 120-volt, single-phase to be used for all control functions except the float circuit and associated relays which shall be provided with 24-volt control voltage.
6. Alternating relay to alternate pumps on each successive cycle of operation.
7. Green run light and H-O-A switch for each pump.
8. Terminal strip to make field connections of pump power leads, float switches, seal sensor leads, heat sensor leads, and remote monitor panel interconnections.
9. Time delay relay to delay start of second pump should power outage occur.
10. All motor starters shall conform to NEMA Standards. IEC sized starters are not allowed.

E. Sensors

1. Incorporate connections for heat sensors which are installed in the pumps. The connection shall disconnect the starter upon high temperature signal and will automatically reconnect when the condition has been corrected.
2. Incorporate connections for seal failure sensors which are installed in the pumps. The panel shall include a seal failure alarm light for each pump to indicate failure of the lower mechanical seals. This will be an alarm light only and will not shut down the pumps.

F. Hour Meter

1. An hour meter for each pump to register the elapsed operating time of each pump.
2. An additional hour meter to register hours of simultaneous pump operation.

G. Protections

1. High-water alarm built into the main enclosure. The high-water alarm shall consist of a flashing alarm light with red lexan plastic cover or red glass globe with metal guard mounted on top of the enclosure such that it is visible from all directions.
2. Alarm horn mounted on the side of the enclosure. Provide a push to test horn and light button as well as a push to silence horn button and mount on the side of the enclosure.
3. Condensate heater to protect against condensation inside the enclosure, placed so as not to damage any other component or wiring in the control center. An air conditioner shall be installed if required by the design Engineer.
4. Lightning protection and a phase monitor relay to shut down the control circuit and protect the equipment due to loss of phase or phase reversal. The three-phase sequence voltage relay shall be of the 8-pin connector type.

H. Manual Select

1. Incorporate an alternator selector switch to allow selection of automatic alternation or manual selection of the lead pump.

I. GFI

1. GFI convenience outlet with 20-amp breaker and suitable transformer or power supply to provide 120-volt single (1) phase power to the convenience outlet.

J. Variable Frequency Drives (VFD)

1. Provide Variable Frequency Drives sized at 110% of motor operation
2. VFD shall be ABB ACQ series or DanFoss Aqua series, no or equals.

K. Miscellaneous

1. One (1) 24" x 24" x 6" hinged NEMA 4X SS cabinet with single locking handle or not more than 2 locking hasps.
2. One (1) Sch 40 PVC conduit for each pump installed to the wet well from the J Box. Size per NEC Chapter 9 tables.
3. One (1) 2" Sch 40 PVC conduit for float cords and transducer installed to the wet well from the J Box.

4. One (1) conduit from the J Box to the main cabinet Conduit shall be sized for the conductors and then filled with gastight filler (silicone or other approved means).
5. One (1) conduit to the main cabinet from J Box for control.
6. Seal the conduits at the entry and exit points of the J box and the control center. The connections in the J box shall be coated with NO-OX to prevent corrosion. There shall be no junction boxes in the wet well basin. All conduits shall be sized per NEC Chapter 9 Tables.
7. Terminals mounted on SS Din rail inside the J Box shall be individually replaceable. Square D model 9080 series or approved equal. Terminations shall be coated with NO-OX.
8. Conduits shall terminate not more than 24" below lift station top of casting (T.O.C.) elevation. Seal conduits to the wet well per Detail 6B.
9. Mount the control center and components on a mounting stand constructed of aluminum. Locate the control center so as to provide safe access to the panel while wet well hatch doors are opened and position so as not to be between the access drive and the wet well.
10. All components of the control center shall be American made and available from local sources. Items such as circuit breakers, overload protection, relays, etc. shall be available and in stock by local sources.
11. Provide an area light on the control panel (250-watt) with an inside switch for night work. Also provide an internal cabinet light.

L. Pump Control Device

1. The pump control device must have at minimum 16 discrete inputs. These inputs must be programmable for the following:
 - a. Low Level Alarm Float
 - b. Pumps Off Float
 - c. Lead On Float
 - d. Lag On Float
 - e. High Level Alarm Float
 - f. Pump In Remote
 - g. Pump Running
 - h. Pump Fail
2. The pump control device must have at minimum 16 discrete outputs. The outputs must be optically isolated, transient protected and be programmable for the following functions:
 - a. Power Fail
 - b. Low Level Alarm/Pumps OFF
 - c. Lead ON
 - d. Lag ON
 - e. High Level Alarm
 - f. Pump In Remote
 - g. Pump Running
 - h. Pump Fail
 - i. Pump Run Command
3. The pump control device must have at minimum 8 Analog Inputs. These inputs must be programmable for the following:

- a. Pump VFD Speed Feedback
 - b. Wetwell Level
4. The pump control device must have at minimum 8 Analog Outputs. These outputs must be programmable for the following:
 - a. Pump Speed Feedback
 - b. Wetwell Level
 - c. Pump Speed Command
 5. Status of the discrete inputs must also be viewable from the front of the pump control device.
 6. The pump control device shall be manufactured by Allen Bradley, CompactLogix Series 5380 and associated I/O.

M. Control and Operation

1. Primary control and operation shall be from a submersible pressure transmitter located in the wet well. There shall also be a secondary control system consisting of a four-float operating system completely redundant and hardwired in the event of a PLC malfunction.
2. Secondary control and operation shall be from non-mercury switches, sealed in a solid polyurethane float for corrosion and shock resistance, to control sump level and alarm signal. The support wire shall have a heavy Neoprene jacket and a weight shall be attached to the cord above the float to hold the float in place in the sump. The floats shall also be capable of supporting themselves from a wiring channel support bar or capable of being attached to a plastic chain with weight at the bottom of the chain. Polypropylene encased mercury float switches are also acceptable. Stainless steel, submersible level transducers may be required at the Utility's discretion.

N. Remote Monitoring

1. The station shall have the ability to be remotely monitored from the Utility's existing SCADA System or utilizing an Omni-Site Crystal Ball for remote alarming capabilities. For remote connections to the Utility's centralized SCADA system, a managed ethernet switch, approved by the Utility's communications group and specified by the project shall be provided. If a remote connection to the Utility's centralized SCADA system is not possible, an Omni-Site Crystal Ball shall be provided as part of the project. Configuration of the Crystal Ball shall be outlined by the ENGINEER as part of the project.
2. At minimum, the remote monitoring system shall monitor the following:
 - a. High water alarm
 - b. Power failure
 - c. Tripping of the overload of any of the pumps
 - d. Signal of seal failure or heat sensor trip of any of the pumps
 - e. High temperature in cabinet
 - f. Low temperatures in cabinet
 - g. Generator Running (if applicable)
3. The remote monitoring system shall alert the Utility's personnel when any of the above conditions occur via an alarm application provided by the Utility's SCADA system or the Omni-Site Guard Dog software application. These alerts shall be provided via SMS

text messaging, email notifications, or voice notifications, as outlined by the project documentation and review by the Utility's personnel.

O. Warranty

1. In order to maintain unit responsibility and warranty on the pumping equipment and control center, the control center must be accepted in writing by the pump manufacturer as suitable for operation with the pumping equipment.

6.05 SITE PROTECTION

- A. Provide new 6-foot high, black, vinyl-coated chain-link fence and gate(s) including braces, fittings, appurtenances, concrete footings, gate operators, electrical, and accessories.
- B. Provide double swing gate. See Detail 6C.

6.06 OPERATION AND MAINTENANCE MANUALS

- A. Submit one (1) hard copy and one (1) PDF copy to the Utility. The manuals shall include, at a minimum:
 1. Operation and Maintenance instructions
 2. Recommended spare parts list
 3. Lubrication schedules
 4. Structural diagrams
 5. As-built wiring diagrams
 6. Bill of materials

6.07 SPARE PARTS

- A. Furnish one set of spare parts for each station. Furnished spare parts shall include:
 1. Impeller
 2. Upper seal assembly
 3. Lower seal assembly
 4. Upper bearing assembly
 5. Lower bearing assembly
 6. Wear rings
 7. O-Rings and gaskets (2 sets)

6.08 STATION WARRANTY

- A. Station warranty shall be three (3) years from the date of acceptance per Utility maintenance bond requirements. Pump warranty shall be as noted in 6.02 G.

6.09 MISCELLANEOUS DESIGN REQUIREMENTS

- A. The wet well storage below the lowest inlet shall be a minimum of 5'0" and shall meet the following criteria.

1. Off float shall be set at the pump manufacturer's recommended level but no less than 1'0 from the bottom of the wet well.
2. The distance between the “off” float and the “lead pump on” float shall be set to provide storage capacity at least equal to five (5) times the rated pump capacity (gpm) with a 15-minute cycle minimum.
3. The “lag pump on” float shall be set a minimum of 6" above the “lead pump on “float and a minimum of 6" below the lowest inlet invert.
4. The “high water alarm” float shall be set a minimum of 6" above the “lag pump on” float and a minimum of 6" below the lowest inlet invert.
5. All float switches shall be set below the lowest inlet invert.
6. A separate low suction float switch connected to the alarm circuit shall be set below the off float.
7. The first section of the influent pipe outside of the wet well shall be ductile iron.
8. A wye fitting with a 6” riser and main line sized per influent pipe size shall be placed in the influent pipe outside of the wet well between the wet well and the plug valve.
9. The Lift Station T.O.C. elevation shall be not less than 36” above the lowest manhole T.O.C. elevation in the collection system feeding said Lift Station.

End of Section 6
Lift Stations

SECTION 7 - DOMESTIC WATER DISTRIBUTION SYSTEM

7.01 GENERAL DESIGN STANDARDS

- A. Design domestic water systems to be owned and operated by NineStar Connect to conform to American Water Works Association (AWWA) Standards and the standards herein.
- B. The Utility, with its Engineer, will dictate the size of the mains required to provide adequate fire protection and to allow for future growth. Early coordination with the Utility is strongly encouraged.
- C. Design water systems with fire hydrants at all intersections and at intervals no greater than 500 feet. Closer hydrant spacing may be required by the Utility depending upon the nature of the development.
- D. Design systems with adequate valves to isolate areas of the system for routine maintenance and repair. Isolation valves are required at all intersections (3 valves at tees; 4 valves at crosses) and at intervals no greater than 600 feet. Tightly group valves and place out of the roadway where possible. The Utility reserves the right to require smaller valve intervals if it believes that the nature of the development necessitates such.
- E. Design and install water mains at depths no less than 54 inches. Hydrants shall be connected to valves by anchor couplings. Valves shall be connected to tees by anchor couplings or other approved joint restraint methods.

7.02 VALVES

A. Gate Valves

- 1. Provide resilient seated gate valves of cast iron body with mechanical joint ends and conforming to AWWA C509.
- 2. Provide valve with bronze stem nuts, glands, and bushings; non-rising stem type with O-ring packing.
- 3. Valves shall open counterclockwise (left) and have a 2-inch operating nut.
- 4. Manufacturer: Mueller Company

B. Butterfly Valves

- 1. Provide resilient seated butterfly valves with mechanical joint ends and conforming to AWWA C501.
- 2. Iron body, bronze retainer, stainless steel shaft type with O-ring packing.
- 3. Provide valves with an underground external operator.
- 4. Valves shall open counterclockwise (left) and have a 2-inch operating nut.
- 5. Manufacturer: Mueller Company

C. Tapping Valves

- 1. Provide iron body, non-rising stem gate valves conforming to AWWA C515. Supply valve gates, gate rings, and body-seat rings which are oversized to permit entry and exit of tapping machine cutters.

2. Valve end connecting to tapping sleeve shall have a flange for bolting to the sleeve. The flange shall have a tongue which fits a recess in the tapping sleeve.
3. Valve end connecting to plain end of water main pipe or adapter shall be mechanical joint.
4. Valves shall open counterclockwise (left) and have a 2-inch operating nut.

D. Tapping Sleeves

1. Stainless steel with a stainless-steel flange end branch connection fabricated in accordance with AWWA C223.
2. Oversized branch connection inside diameter to permit entry and exit of tapping machine cutters.
3. Flange end shall have a recess to center the tapping valve.

E. Inserting Valves

1. Insertion valve must be installed by a certified professional.
2. Provide tapping valve and sleeve assembly designed to drill and ream the pipe and install insertion valve without any interruption to water service.
3. Provide valve assembly containing a ductile iron casting inset coated with styrene butadiene rubber compound and which seals on the inside diameter of the insertion valve sleeve neck and the lower half of the water main.
4. Valve stem and nut assembly: conforming to AWWA C500.
5. Bolts, nuts, and washers: Type 304 stainless steel
6. Tapping sleeve: ASTM A36 steel
7. Coating: epoxy coated to 10-12 mils; lined and coated with fusion-bonded epoxy meeting the requirements of AWWA C213.
8. Gaskets: styrene butadiene rubber (SBR) compound which provides a positive 360-degree seal on the pipe and with a resilient seal at the pipe sleeve and valve insertion junction.
9. Valves shall open counterclockwise (left) and have a 2-inch operating nut.
10. Provide inserting valve and sleeve assembly as manufactured by Romac Industries, Inc. or approved equal.

F. Air Release Valves

1. Cast iron body, cover and baffle, with stainless steel float brass water diffuser and Buna-N seat.
2. Install air release valves in vented meter boxes as shown in detail included in these standards.
3. Manufacturers
 - a. Model 200A as manufactured by APCO Valve
 - b. Model #VM22 as manufactured by Val-Matic Corp.
 - c. Or approved equal.

G. See Detail 7A for Air Release Valve.

1. Valve Boxes
2. Outside of Pavement: Supply all buried valves with posi-cap and appropriately sized smooth walled PVC riser box above with CI Valve box lid. Use detail 7B for any valve within greenspace

3. Within Pavement: Supply all buried valves with 5 ¼” Sigma VB266-8 screw type or Tyler 29U Series screw type valve box and components. Use detail 7C for any valve that needs to be placed in pavement
4. Provide with removable cast iron lid with the word “water” marked on it.
5. Provide with a posi-cap for stabilization and centering.
6. Provide all valve boxes located outside of traffic areas with a six-foot long steel fence post, painted blue.
7. Provide valve boxes as shown in detail included in these standards.

7.03 HYDRANTS

- A. Provide hydrants conforming to AWWA C502 and as follows.
 1. Provide Mueller Super Centurion 250 with Aquagrip System.
 2. Two (2), 2-1/2-inch NST connections and one (1) 5 ¼”Storz connection.
 3. Open counterclockwise (left).
 4. Provide each hydrant with a 2-component exterior grade full gloss polyurethane exterior enamel topcoat. Touch-painting in the field shall be in accordance with the manufacturer’s recommendations.
 5. 6-inch auxiliary gate valve
 6. One (1) operating wrench for every ten (10) hydrants supplied
- B. Provide hydrants as shown in Detail 7D included in these standards.
- C. Breakoff flange should be set 4-6” above final grade.
- D. Flush hydrants shall be Mueller A411.
- E. Provide Copperhead Cobra Access Point T-2 tracer wire assembly and conduit at every hydrant.

7.04 BLOW-OFF ASSEMBLIES

- A. Provide temporary blow-off assemblies used for flushing and testing in accordance with detail include in these standards.
- B. See Detail 7E for a standard hydrant / blow off bleed.
- C. See Detail 7F for standard hydrant to blowoff bleed.

7.05 LINE STOPS

- A. Line stop sleeve
 1. Fabrication: Type 304 Stainless Steel in accordance with AWWA C223. Provide fully passivated line stop sleeve to return the stainless steel to its highest corrosion resistance.
 2. Pass through bolt design and 360-degree seal around the full circumference of the pipe.
 3. Body construction of a minimum of 12-gauge stainless steel for the outlet half (load bearing half) and 14-gauge stainless steel for the back half (conforming half).
 4. Provide line stop sleeve with schedule 40 stainless steel pipe sized to accept a full-sized cutter.

5. Flange: stainless steel, 18-8 Type 304 ANSI 150 Drilling, recessed for tapping valve per MSS-SP60.
 6. Rated at 150 psi for hydrostatic with a test pressure of 200 psi on pipe with a circumferential break.
- B. Bolts, nuts, and washers: Type 304 Stainless Steel. Provide track head type bolts furnished with permanently lubricated heavy-hex nuts and stainless washers.
 - C. Provide Styrene-Butadiene Rubber (SBR) gaskets.
 - D. Provide Model 440 Line Stop Sleeves as manufactured by JCM or approved equal.

7.06 TRACER WIRE

- A. Install tracer wire with all pipe as shown on Drawings.
- B. Provide solid 12-gauge AWG copper wire.
- C. Supply 3M Direct Bury splice kits (KIK 3M) consisting of tubes prefilled with silicone electrical insulating gel or approved equal.
- D. On pipe installed by horizontal bore, pull 2 strands of tracer wire with pipe. Provide Copperhead Direct Burial 12 AWG solid, steel core hard drawn extra high strength.

7.07 WATER MAIN

- A. Ductile Iron (DI) Pipe
 1. Provide pipe conforming to AWWA C151 with a minimum of:
 - a. 350 PSI rated working pressure for 12-inch diameter and smaller pipe
 - b. 250 PSI rated working pressure for 14-inch diameter and larger pipe
 2. Markings: Each length of pipe and fittings shall be plainly stamped or indelibly marked, or color coded as to the weight, class, and type, and include the manufacturer trademark or name and the National Sanitation Seal of Approval.
 3. Lining and coating: Standard cement mortar lined, and seal coated with an approved asphaltic seal coat in accordance with AWWA C104 (ANSI A21.4). Coat the exterior surfaces with an approved bituminous coating meeting the requirements of AWWA C110 and AWWA 151 (ANSI 21.51).
 4. Pipe joint and gasket: push-on type joints and gaskets conforming to AWWA C111. O-ring gaskets sealing the slip joint shall be made of rubber of special composition having a texture to assure a watertight and permanent seal, and be resistant to common ingredients of sewage, industrial waste and groundwater, and which will endure permanently under the conditions likely to be imposed by this service.
 5. Provide Tyton Joint pipe as manufactured by U.S. Pipe, Fastite Joint pipe as manufactured by American, or approved equal.
- B. Polyvinyl Chloride (PVC) Pipe C900 or C905 (Ductile Iron O.D.)
 1. Provide pipe conforming to AWWA C900 or C905 as applicable and having a dimension ratio of:
 - a. DR-18 for 12-inch diameter and smaller pipe

- b. DR-25 for 16-inch diameter and larger pipe
2. Pipe materials: conform to ASTM Specification D-1784, Class 12454-B.
3. Pipe joint and gasket: push-on type joints conforming to ASTM D-3139. Gaskets shall conform to ANSI Standards A21.11. Single bell and spigot type, the bells being formed integrally with the pipe; bell consisting of a factory-installed solid cross section elastomeric gasket which meets the requirements of ASTM F477.
4. Provide J-M Eagle, North American Pipe Corporation, National Pipe and Plastics, Inc., or approved equal.

C. Ductile Iron Fittings

1. Provide ductile iron fittings standardized for the type of pipe and joint specified. Fittings shall comply with AWWA C110 (ANSI A21.10) and have standard thickness cement mortar lining as specified in AWWA C104 and a bituminous seal outside coating as specified in AWWA C151.
2. Gaskets: conforming to AWWA C111.

D. Fitting Restraints

1. Series 1100 Megalug by EBAA Iron for DI pipe (3- to 48-inch diameter)
2. Series 2000 PV Megalug by EBAA Iron for C900 or C905 PVC pipe (3- to 36-inch diameter)
3. JCM 610 Sur-Grip Restrainer by JCM for DI pipe (4- to 12-inch diameter)
4. JCM 610 Sur-Grip Restrainer by JCM for C905 PVC pipe (14- to 30-inch diameter)
5. Ford Meter Box Uni-Flange Series 1400 Restrainer for DI pipe (3- to 36-inch diameter)
6. Ford Meter Box Uni-Flange Series 1500 Restrainer for C900 pipe (3- to 36-inch diameter)

E. Pipe Joint Restraints

1. Series 1500/1600 Bell Restraint Harness by EBAA Iron for C900 PVC pipe (4- to 12-inch diameter)
2. Series 2800 Megalug Restraint Harness by EBAA Iron for C905 PVC pipe (14- to 48-inch diameter)
3. Series 1700 Megalug Restraint Harness by EBAA Iron for DI pipe (4- to 48-inch diameter)
4. Field Lok 350 Gaskets by U.S. Pipe & Foundry Company for DI pipe (4- to 24-inch diameter)
5. Flex-Ring Joint System by American Ductile Iron Pipe for DI pipe (14- to 48-inch diameter)
6. JCM 620 Sur-Grip Bell Joint Restrainer for DI or C900 PVC pipe (4- to 12-inch diameter)
7. JCM 621 Sur-Grip Bell Joint Restrainer by JCM for C905 PVC pipe (14- to 30-inch diameter)
8. Ford Meter Box Uni-Flange Series 1390 Joint Restrainer for C900 or C905 PVC pipe (4- to 36-inch diameter)
9. Ford Meter Box Uni-Flange Series 1390 Joint Restrainer for DI pipe (black body) (4- to 16-inch diameter)

F. Nuts and Bolts

2. Furnish high strength, heat-treated cast iron nuts and bolts which conform to AWWA C111. Nuts shall be hexagonal, and bolts shall be tee head.

G. Polyethylene Encasement

1. Provide polyethylene encasement for use with ductile iron pipe and fittings conforming to ANSI/AWWA C105/A21.5
2. Encasement: three layers of co-extruded linear low-density polyethylene, fused into a single thickness of not less than 8 mils. The inside surface of the wrap to be in contact with the pipe exterior shall be infused with a blend of anti-microbial biocide to mitigate microbiologically influenced corrosion and a volatile corrosion inhibitor to control galvanic corrosion.
3. Provide V-Bio Enhanced Polyethylene Encasement as manufactured by U.S. Pipe, or approved equal.

H. High Density Polyethylene (HDPE) Pipe

1. Provide pipe conforming to AWWA C901 and C906, manufactured from high density, extra high molecular weight polyethylene and conforming to PE Standard Code PE 4710. Pipe shall have a minimum cell classification of 445574C per the requirements of ASTM D3350.
2. Markings: blue shell or blue permanent striping and AWWA specification stamp embedment or permanent blue-line print clearly and continuously marked longitudinally along the outside pipe wall.
3. Designed and manufactured in iron pipe size and to the pressure class specified. The pipe Dimension Ratio (DR) shall be used to determine the pressure rating classification. Pipe shall be designed to withstand crushing, buckling and deformation resulting in ovality at the specified depth of bury.
4. Deflection: Do not deflect pipe on a radius of more than 80% of the allowance recommended by the manufacturer.

I. HDPE Fittings

1. Provide fittings manufactured from high density, extra high molecular weight polyethylene which conforms to PE Standard Code PE 4710. Fittings shall have a minimum cell classification of 445574C per the requirements of ASTM D3350.
2. Provide fabricated polyethylene fittings designed and manufactured for one pressure class rating higher than the pressure class rating of the pipe specified.
3. Manufactured per the requirements of ASTM D3261; injection molded or fabricated using a combination of extrusion and machining. Supply HDPE fittings manufactured or fabricated in facilities designed for that purpose. Field fabricated HDPE fittings are not allowed.
4. Fitting markings: blue shell or permanent blue striping and the AWWA pipe specification stamp embedment or permanent blue-line print clearly and continuously marked longitudinally along the outside pipe wall.

J. HDPE Flange Backup Rings and Gaskets

1. Provide flange backup rings conforming to AWWA C207; Class D with bolting dimensions conforming to ASTM B16.5.

2. Flange backup ring coating: fusion-bonded epoxy applied to all exterior and interior exposed surfaces with a minimum dry film thickness of 4 mil.
3. Flange gaskets: synthetic red rubber (SBR) hardness (Shore A) 80 +/- 5, ring or full face, 1/8-inch thick and conform to ASTM D1330 grades I and II. Asbestos gaskets are not allowed.

K. Bolts and Nuts

1. Flange to flange connection bolts: carbon steel, ASTM A307 grade B for Class D flanges.
2. Nuts conforming to ASTM A194 grade 2H.
3. Furnish bolts and nuts having regular unfinished hexagonal dimensions in accordance with ASTM B18.2.1 for wrench head bolts and nuts and wrench openings.
4. Minimum bolt lengths shall be the sum of the mating flange maximum thicknesses, the gasket and the depth of nut plus 1/8 inch minimum before torquing.

L. HDPE Mechanical Joints

1. Use polyethylene mechanical joint adaptors when making connections to mechanical joint fittings and when connecting to dissimilar pipe materials such as PVC or ductile iron.
2. Connect polyethylene adaptor to mechanical joint fitting using a mechanical joint gland and gasket and in accordance with the specifications regarding mechanical joint ductile iron fittings. Meg-A-Lugs and Field-Lok gaskets are not allowed for use with polyethylene mechanical joint adaptors.
3. Provide "Harvey" style polyethylene mechanical joint adaptors that include a stainless-steel stiffener inserted into the inside of the mechanical seal end of the adaptor to provide additional axial strength and prevent pipe diameter reduction at the seal.
4. Provide mechanical joint adaptors as a kit complete with gasket, mechanical gland, bolts and nuts per this section.
5. See Detail 7G for HDPE Pipe Transition and 7H for HDPE Fitting Transition.

7.08 SERVICES AND METER PITS

- A. Saddles - Provide saddles (for PVC pipe only) cast from 85-5-5-5 waterworks brass and manufactured and tested in accordance with AWWA C800. Supply Series S-13000 (hinged) as manufactured by Mueller Company, or approved equal.
- B. Service Lines – Provide 1-inch polyethylene from the water main to the meter pit and ¾" polyethylene from the pit to the consumer constructed with a pressure rating of 200 psi. Provide Mueller 110 compression fittings. Conform to ASTM D2737 and AWWA C901. Larger service lines may be necessary for larger water consumers.
- C. Meter Pit and Brass Fittings – Provide meter pit and materials as shown on detail included in these standards.
- D. Set meter pits only after all other utilities are installed. Pits are to be set within 3-5 feet behind of sidewalk and +/- 3" of final grade.
- E. See Detail 7I for Water Meter and Service Line.

F. See Detail 7J for Vault Metering.

7.09 BACKFLOW PREVENTION

- A. A backflow prevention device is required to be installed where any water line from an auxiliary water supply enters or passes within one (1) foot of any part of a commercial or industrial facility, all irrigation systems, or any service connections designated to have a potential cross connection hazard.
- B. The backflow prevention device shall be a University of Southern California (USC) or other IDEM approved device and shall be installed in a location approved by the Utility. The device must be periodically tested by an Indiana registered cross connection control tester at intervals determined by IDEM.
- C. Service connections to facilities designated as a cross-connection hazard by 327 IAC 8-10-4(c) shall be equipped with either an air gap or reduced pressure principle backflow preventer in accordance with 327 IAC 8-10-7.

7.10 SPECIAL CROSSINGS

A. Steel Casing Pipe

- 1. Provide welded steel pipe conforming to ASTM A139 Grade B for “Electric Fusion of Welded Steel Pipe” with minimum yield of 35,000 psi.
- 2. Inside diameter at least 6 inches greater than the largest bell diameter of the carrier pipe.
- 3. Provide when casing pipe needs to be 24 inches or larger.
- 4. Provide where crossing State Highways and railroads.
- 5. Minimum wall thickness:
 - a. 0.250 inches – pipe diameter 18” and less
 - b. 0.375 inches – pipe diameter 20” to 26”
 - c. 0.500 inches – pipe diameter 28” to 42”
- 6. See Detail 7K for Casing Pipe.

B. HDPE Casing Pipe

- 1. Pipe conforming to the requirements of this Section.
- 2. Inside diameter at least 6 inches greater than the largest bell diameter of the carrier pipe.
- 3. Provide when casing pipe needs to be less than 24 inches.
- 4. Dimension ratio DR-9
- 5. See Detail 7K for Casing Pipe.

C. Casing Spacers

- 1. Meet all applicable American Water Works Association (AWWA) Standards
- 2. Provide as shown on detail included in these standards.
- 3. See Detail 7L for Casing Spacer.

D. Pipe Joint Restraints in Casing Pipe

- 1. Provide restrained joints for all pipe installed in steel casing.
- 2. Ductile Iron Pipe

- a. TR Flex RJ pipe by U.S. Pipe (4"-36")
 - b. HP Lok RJ pipe by U.S. Pipe (30"-64")
 - c. Fastite Joint Pipe with Fast-Grip Gasket by American (4"-24")
 - d. Flex-Ring Joint Pipe by American (14"-54")
 - e. Approved equal with any pipe joint restraints listed in Article 7.07E as applicable, with the exception of Field Lok 350 gaskets by U.S. Pipe which shall not be used within casing.
3. PVC Pipe
 - a. Certalok Yelomine Restrained Joint Pipe as manufactured by Certainteed.
 - b. Approved equal with any pipe joint restrain listed in Article 7.07E as applicable.
 4. See Detail 7M for Waterway Crossing.

7.11 INSTALLATION

A. General

1. Install water mains, fittings, valves, hydrants, and other appurtenances as specified in these standards. Provide proper implements, tools, and facilities for the safe and expeditious performance of the work. Do not install pipe when, in the opinion of the Utility Representative, trench conditions are unsuitable.
2. Inspect valves and hydrants in open and closed positions to ensure all parts are in working condition.
3. Inspect water mains, fittings, valves, hydrants, casing, and appurtenances prior to installation and promptly remove damaged or unsuitable materials from the job site. Replace damaged or unsuitable materials.
4. Clean each length of pipe, fitting, and valve of all debris, dirt, and other foreign material before laying and keep clean until accepted as completed work.
5. Lay and maintain pipe to the lines and grades shown on the approved plans unless otherwise allowed by the Utility. Install fittings, valves, and hydrants in the locations shown on the approved drawings.
6. Where the piping is to be constructed parallel to and close to existing buried utilities, the exact location of which is unknown, adjust the alignment of the piping to least interfere with these utilities.
7. Do not lay pipe in water or when the trench or weather conditions are unsuitable for proper installation.
8. Lower pipe, fittings and valves into the trench by hand, by means of hoists or ropes, or by other suitable tools or equipment which will not damage materials, coatings, or linings. Do not drop or dump pipe, fittings, or valves.
9. As each length of pipe is placed in the trench, assemble the joint, and bring the pipe to the correct line and grade and secure in place with bedding tamped under and around each side of the pipe. Deposit and compact backfill material uniformly and simultaneously on each side of the pipe to prevent lateral displacement. Excavate bell holes in advance of pipe laying so the entire barrel will bear uniformly. Lay pipe with bell ends facing in the direction of laying.
10. Install temporarily plugs in installed piping systems at the end of each day's Work or other interruption of progress on a given line. Install plugs in a manner satisfactory to the NineStar Connect, and ensure plugs are adequate to prevent the entry of animals into the pipe or the entrance or insertion of deleterious materials.
11. Excavate trenches to widths which provide adequate working space for proper pipe installation, jointing and embedment. Shape the bottom of trench to give uniform

circumferential support to the lower quarter of each pipe. Lay pipe with bell ends facing in the direction of laying.

12. For DI fittings with mechanical joints that require harnessing, provide DI mechanical joint retainer glands. For DI push-on joints that require harnessing provide push-on gripper gaskets. Use a stencil and paint the word "HARNESSED" in 2-inch safety orange letters on the top of the bell on each push-on joint assembled with a gripper gasket. Do not use gripper gaskets when installing plugs.

B. Minimum Separation

1. Lay potable piping at least ten (10) feet horizontally from any existing sanitary sewer, sewage force main, or storm sewer. The distance shall be measured from edge of pipe to edge of pipe.
2. Lay potable water piping crossing sanitary sewers or sewage force mains to provide a minimum vertical distance of 18 inches between the outside edge of the potable water piping and the outside edge of the sewer force main. The 18-inch separation shall apply whether the potable water piping is over or under the sewer or force main. Lay potable water piping at crossings of sewers and force mains so a full length of pipe is centered on the sewer.
3. See Detail 5C for minimum crossover and separation requirements for sewer and water mains.

C. Joint Restraints

3. Provide joint restraints at horizontal and vertical deflection fittings and at tees, caps, reducers, bends, plugs, tapping sleeves, and tapping saddles. General joint restraint details and lengths are shown in Detail 7N included in these standards.

D. Open Excavation

1. Secure open excavation at all times. At the end of each day's work, protect the open ends of all pipes against the entrance of animals, children, earth, or debris by bulkheads or stoppers. Earth or other material that finds entrance into the watermain through open end must be removed at the Contractor's expense.

E. Magnetic Locator Wire

1. Install tracer wire on plastic (PVC, HDPE) pipe by taping to pipe in 15- to 20 foot intervals. Do not wrap wire around pipe. Install tracer wire on inside of all valve boxes with enough wire to extend 2 feet above the box. Seal splices and branch connections with epoxy and wrap with tape. Provide a continuity test on all tracer wire installed.
2. On pipe installed by horizontal directional drill, pull a minimum of 2 strands of tracer wire with pipe. Provide Copperhead Direct Burial 12 AWG solid, steel core hard drawing extra high strength wire. Assemble tracer wire splices and branch connections with 12 AWG splice kits suitable for underground installation. Remove 1/2 inch of insulation from wire. Tie together wires using an overhand knot to prevent pull apart and use a split bolt connector or solder to connect for electrical continuity. Seal connection with epoxy contained in splice kit and wrap with tape.

F. Location Material

1. Provide non-detectable tape such as Terra Tape Non-Detectable Standard Tape, as manufactured by Reef Industries, Inc. or approved equal.
2. Provide blue location material marked with "Caution Water Line Buried Below."

7.12 PIPE BEDDING, HAUNCHING, AND BACKFILL

- A. Lay each length of pipe in a firm foundation of bedding material and haunch and backfill with care.
- B. Place Bedding, Haunching, and Initial Backfill materials in 6 to 8-inch balanced lifts to ensure proper compaction and filling of all voids.
- C. Uniformly compacted, clean granular bedding shall be installed below all water mains. Bring bedding material to grade along the entire length of pipe to be installed. Use hand or mechanical tamping to compact the bedding material to a minimum 95% Standard Proctor Density.
- D. Use procedures and equipment for the Standard Proctor compaction test in accordance with ASTM D698/AASHTO T99.
- E. Class II Material: for the first 24 inches of backfill over pipe, use hand operated tamping devices. Use standard mechanical methods for the remainder of the trench.
- F. Do not flood or puddle with water to consolidate backfill.
 1. When compaction test results are unsatisfactory, re-excavate, re-compact the backfill and retest until the specified compaction is obtained.
- G. In yielding subsoils, undercut the trench bottom to the depth necessary and backfill with graded, crushed stone to form a firm foundation.
- H. Embodiment material shall be placed around flexible pipe. Place Class II backfill between the bedding material and to 12 inches over the top of the pipe. If fine sand, silt, or clayey gravels are used for initial backfilling over the pipe, place in 6 to 8-inch layers and compact on both sides of the pipe to an elevation 12 inches over the top of the pipe.
- I. Trench widths and bedding requirements shall, conform to manufacturer's recommendations, AWWA/ASTM Standards, and these standards. Where conflicts exist, the most stringent shall apply.
- J. Unless otherwise shown on plans, rigid pipe, such as ductile iron, shall be backfilled between the bedding material and a height of 12 inches over the top of the pipe with hand placed finely divided earth, free from debris and stones.
- K. Place trench backfill in balanced lifts to ensure proper compaction and filling of all voids.
- L. Granular backfill shall be used in accordance with INDOT Standard Specifications. Place all granular fill and achieve compaction of not less than 95% of the maximum dry density as determined in accordance with AASHTO T99, Method A (Std. Proctor) for the entire depth of the excavation. The manner in which the contractor achieves proper compaction shall be demonstrated at the beginning of the project (first 1,000 cu. yd.) and this method

shall be used for the duration of the project. Use an independent testing agency to verify proper compaction.

- M. Upon approval, flowable fill may be used to fill trenches for pipe and structures under pavement, and other locations. Installation, materials, and construction requirements shall be in accordance with INDOT Standards.
- N. Backfill and bedding shall be as shown on the detail included in these standards unless approved in writing by NineStar Connect.
- O. Backfill all trenches within State Highway right-of-way in accordance with INDOT specifications. Backfill all trenches within the right-of-way of other public authorities having jurisdiction in accordance with requirements of the public authority.
- P. For any trench that intersects any portion of the pavement/structure loading zone use Class II backfill materials.
- Q. For any utility located in proximity to a building foundation use 2:1 structure lading zone rule for the placement of compacted bedding and backfill materials.
- R. See Detail 5J for Ductile Iron Pipe Trench and Detail 5I for Flexible Pipe Trench.

7.13 PIPE ASSEMBLY

- A. Assemble joints in accordance with the manufacturer's instructions.
 - 4. Properly apply the manufacturer's lubricant where applicable.
 - 1. Center spigot ends in the bell of the pipe and push the pipe home bringing it to the correct line and grade. Remove pipe and fittings that do not allow a sufficient and uniform space for joints and replace with pipe of proper dimensions.
 - 2. Prevent dirt or other materials from entering the joint space.
- B. When it is necessary to deflect pipe from a straight line in either the horizontal or vertical plane, the amount of joint deflection shall not exceed 80% of the allowance recommended by the manufacturer. If alignment results in excess joint deflection, install additional fittings or shorter lengths of pipe.
- C. Cut pipe for insertion of valves, fittings, or closure pieces in conformance with recommendations of the manufacturer of the pipe and cutting equipment. Cutting shall be done in a safe, workman like manner without creating damage to the pipe lining. An oxyacetylene torch shall not be used. Ends and rough edges shall be ground smooth. Bevel the cut ends of push-on joint connections using methods recommended by the manufacturer. For bell and spigot joint installation, bevel the edges of all field cut pipe after cutting. For mechanical joint installation do not bevel the pipe end. Remove all burs that form as a result of field cutting the pipe, whether the pipe end is beveled or not.

7.14 SERVICE LINE INSTALLATION

- A. Install service lines within the public Right-of-Way in accordance with these standards, AWWA C800 and the Uniform Plumbing Code.

- B. Where new meters are installed on opposite sides of the road from new mains, push services under the road to connect to meters. No open cutting of road surfaces will be allowed for service lines.
- C. Install meter pits at Right-of-Way property lines or as directed by the Utility. Set meter boxes plumb and adjust meter box covers so they are flush with the finish grade (+/- 1 inch).
- D. Install, flush, and perform leakage tests on service lines in accordance with the Uniform Plumbing Code.
- E. Where new meter pits are to be installed and existing meter pits are to be removed, re-install existing meter read equipment in the new meter pits at the direction of the Utility.
- F. For developments with new street curb, stamp the top of curb with a "W" at locations of water services.

7.15 HYDRANT INSTALLATION

A. Placement

1. Place fire hydrants at all intersections and at intervals no greater than 500 feet or as shown on the Drawings.
2. Hydrants shall be installed in locations to provide complete accessibility. Placement shall reduce the possibility of damage from vehicles or injury to pedestrians.
3. Hydrants to be set 2' behind sidewalk (if applicable).
4. When placed behind the curb, set the hydrant barrel so that no portion of the hose nozzle cap will be less than 2 feet nor more than 6 feet from the gutter face of the curb.
5. When set in lawn space between the curb and the sidewalk, or between the sidewalk and property line, no portion of the hydrant or nozzle shall be within 6" of the sidewalks.
6. For hydrant installation in a cul-de-sac, see Detail 7O.

B. Installation

1. Hydrants shall stand plumb and be situated so that side nozzles face the curb at a 90-degree angle. If located on private property or a rural road, the nozzle shall point to the nearest roadway. Connect hydrant to the main with a minimum 6" diameter branch unless otherwise shown on plans.
2. Provide hydrant extensions where required to obtain the proper elevation.
3. Hydrants shall have 3 cubic feet of "L" rock, No. 8 Stone, washed, or other approved stone no smaller than 3/4" diameter placed around the base of the barrel for drainage capacity. Provide stone from the bottom of the trench to a minimum of 6" above the waste opening in the hydrant elbow.
4. During construction, place a bag over new hydrants that are not ready for service. Remove the bag after the water main has been tested and placed in service.
5. Hydrants shall be tied to the pipe with suitable anchor couplings, or restrained joints.
6. Install hydrants with a minimum bury not less than that required for the water mains. Check the hydrant locations and determine whether the hydrant requires a deeper bury depth.
7. Install hydrant extensions where required to obtain proper elevation. Install a gate valve and valve box on each hydrant branch connection. Bag/cover all hydrants that have been

installed but are not ready for service. Remove bag/cover when hydrants are ready for service.

C. Restraint

1. Hydrants and auxiliary valves shall be installed with a manufactured thrust restraint system, or stainless steel all threads, to stabilize valve and hydrant under all operating conditions including removal and replacement activities.

7.16 FUSION BONDING PROCEDURE FOR HDPE PIPE

A. General Fusion Bonding Procedure

1. Piping joints and fittings, other than those shown as flanged or otherwise mechanically connected, shall be butt heat fusion bonded in accordance with the requirements of ASTM F2620.
2. The joining method shall be performed in strict accordance with the pipe manufacturer's requirements.
3. Heat and fuse the ends of two pipes together to form a leak free bond and joint weld strength at least equal to the tensile strength of the pipe.
 - a. Prepare pipe ends by clamping and facing.
 - b. Put the ends contact with the heater until the appropriate size bead is formed.
 - c. Remove the heater and bring pipe ends together with the force required to form the fusion bead. Maintain this force until the pipe joint has cooled.
4. Electrofusion method of joining shall not be used except to connect adjacent directionally drilled sections in the trench bottom or for service saddles installed in the trench bottom.

B. Fusion Equipment

1. Fusion equipment shall be:
 - a. Capable of meeting all parameters of the job and be in proper operating condition. Test and certify equipment heater performance each day at start up prior to use for fusion bonding, and one other time during the day no sooner than 4 hours after starting up.
 - b. Designed to properly hold the size of the pipes being fused, and have enough hydraulic force to reach the required fusion pressure during all fusion conditions.
 - c. Capable of meeting all conditions required by the pipe manufacturer, including temperature, alignment, and fusion pressure.
 2. Each butt fusion joint shall be logged electronically by the fusion equipment, for quality control, by such equipment as DataLogger[®] manufactured by McElroy Manufacturing, Inc. Logged fusion joints shall be stored in the data logger unit, so the records can be downloaded and printed weekly for submittal to NineStar Connect.
1. Remove one fusion joint for every five days of fusing bonding Work and forward to a certified lab for testing. Include bend back tests of the fused joint per AWWA C906.
- C. Allow HDPE pipe to reach ambient temperature for the installed condition before final cutting, installation of concrete restraint system, or connection of transition couplings.

7.17 VALVE INSTALLATION

- A. Place valves vertically on solid concrete block as shown on Drawings and bed them solidly. Center valve box over operating nut. Place and compact backfill in lifts around valve box so valve box remains plumb. Tamp backfill on all sides of each valve box to the undisturbed trench face. Adjust valve box covers so they are flush with finish grade. Re-adjust covers as necessary so that they remain flush with the finished grade after final paving and grading Work is complete.
- B. All live taps to be completed by a certified contractor.

7.18 TESTING AND DISINFECTION TAPS

- A. Water mains shall be flushed, tested and disinfected in accordance with Section 4.06 of these Rules and Standards.

7.19 SERVICE TAPS

- A. Service taps will be reviewed and approved by the Utility on a case by case basis. An observer from the Utility must be present during the tap. Schedule tap appointments 48 hours in advance of construction.
- B. Submit a site plan showing service line location, sump discharge line, meter pit and location of proposed service line prior to issuance of a permit.
- C. Excavation trench must comply with OSHA requirements. A minimum of 36" shall be provided between the water main and trench wall during installation. The bottom of the trench must be a minimum of 12" below the bottom of the main and 18" behind the main.
- D. Keep the trench bottom dry and free from water. Place stone in unstable or wet trench bottoms.
- E. No taps shall be made within 3 pipe diameters of fittings or bells or within 7 feet of a hydrant.
- F. All live taps to be completed by a certified contractor.

End of Section 7
Domestic Water Distribution System

Drawing: C:\Users\mason\OneDrive - Wessler Engineering\Incl\Desktop\NEW\WINESTAR DETAILS (AUGUST 2024)\MIN ELEVATION FOR GRAVITY CONNECTION.dwg | Layout: Sd1.f | Plotted: 08/11/24 @ 10:42:09 | LastSavedBy: Mason.F

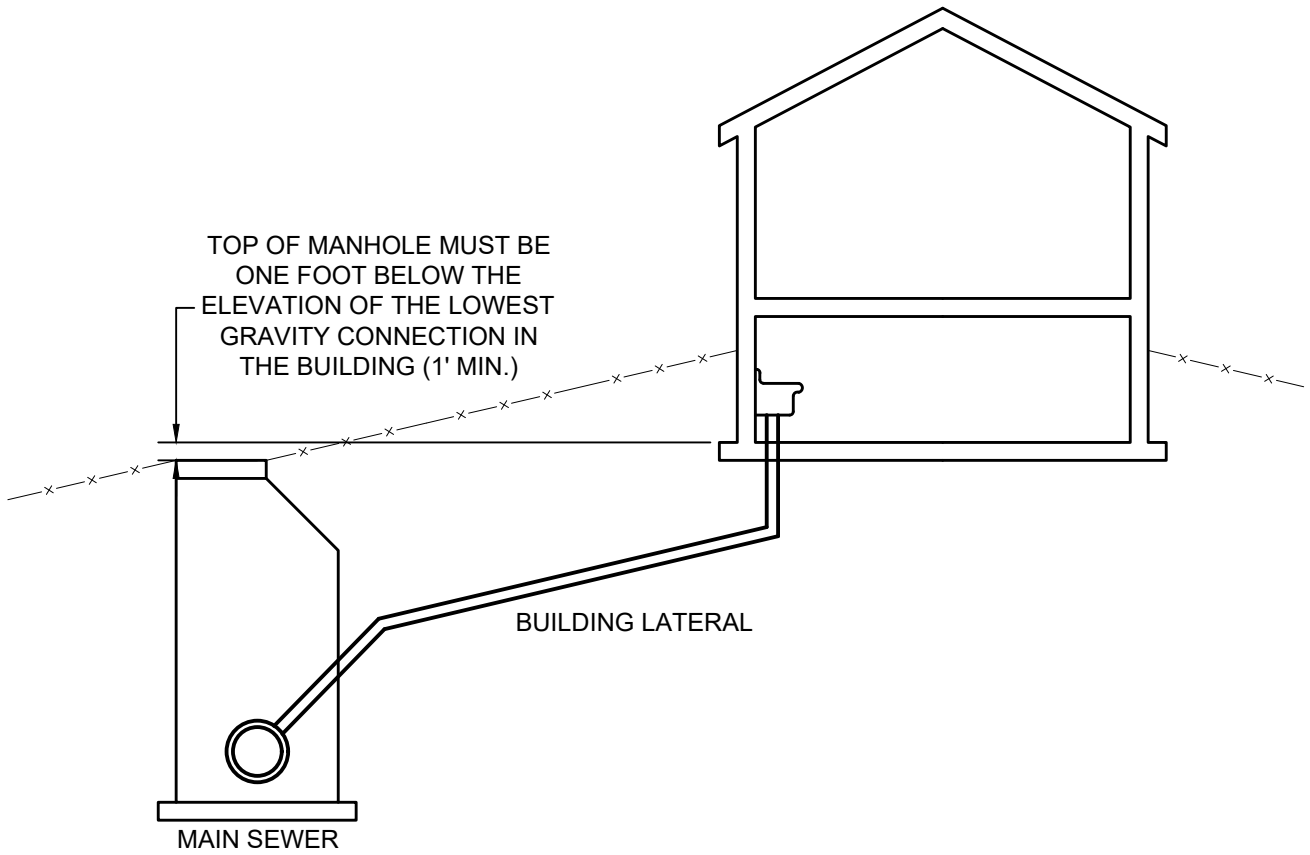

MIN. ELEVATION FOR GRAVITY CONNECTION

DETAIL NO. 5A
DATE: 9/11/2024

Drawing: Y:\Wessler Groups\Cad Users\Autocad Training\MTF\REVISED DETAIL SHEETS\NEW NINESTAR DETAILS (AUGUST 2024)\RESIDENTIAL GRINDER STATION INSTALLATION.dwg | Layout: Std1 | Plotted: 11/25/24 @ 08:22:09 | LastSavedBy: Mason.F

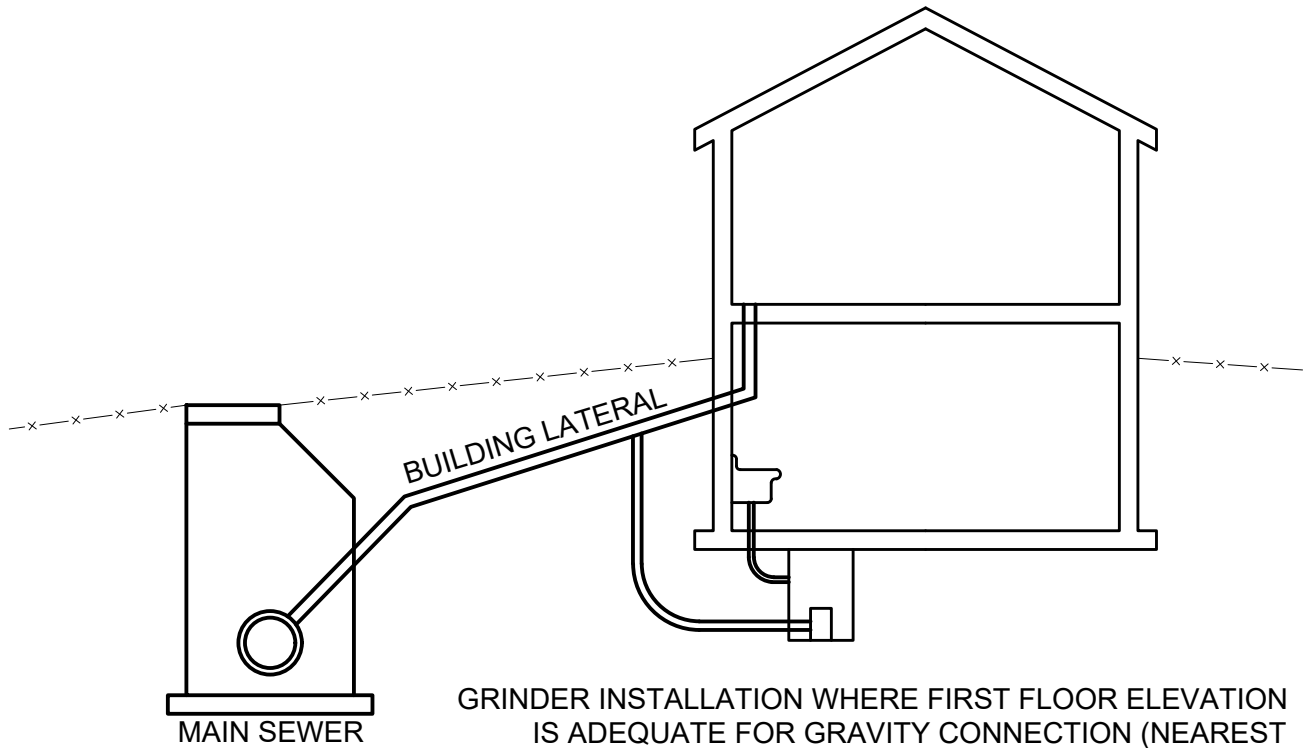

GRINDER INSTALLATION WHERE FIRST FLOOR ELEVATION IS ADEQUATE FOR GRAVITY CONNECTION (NEAREST MANHOLE IS AT LEAST ONE (1) FOOT BELOW FIRST FLOOR).



RESIDENTIAL GRINDER STATION INSTALLATION

DETAIL NO. 5B
DATE: 11/25/2024

Drawing: C:\Users\mason\OneDrive - Wessler Engineering\Inc\Desktop\NEW WINESTAR DETAILS (AUGUST 2024)\MIN CROSSOVER & SEPARATION REQUIREMENTS FOR SEWER & WATER MAINS.dwg | Layout: 8.5x11 Std | Plotted: 09/11/24 @ 10:46:29 | LastSavedBy: MasonF

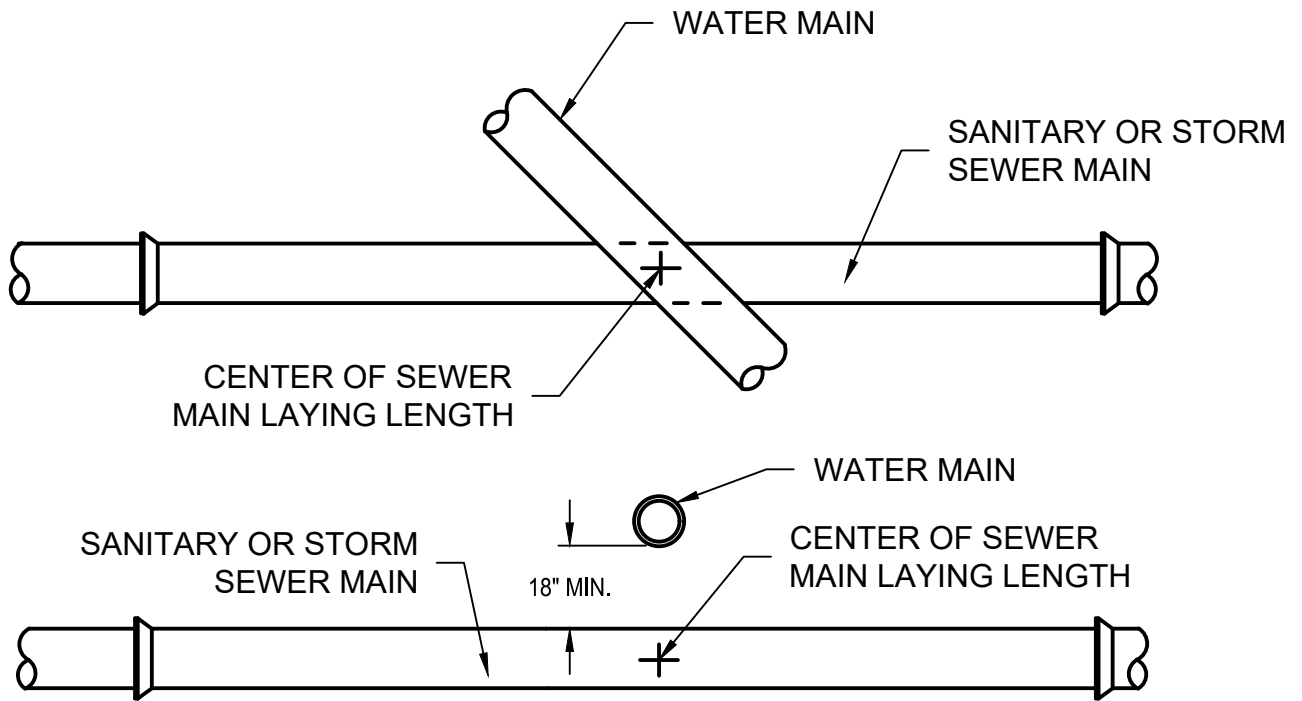

NOTES:

1. WATER MAIN AND SEWER MINIMUM SEPARATION: 18" VERTICAL SEPARATION 10'-0" HORIZONTAL SEPARATION.
2. WHERE WATER MAIN AND SEWER SEPARATION IS LESS THEN 18" VERTICAL OR 10" HORIZONTAL, THE SEWER MUST BE DUCTILE IRON OR SDR-21 PVC.



MINIMUM CROSSOVER & SEPARATION REQUIREMENTS

DETAIL NO. 5C
DATE: 9/11/2024

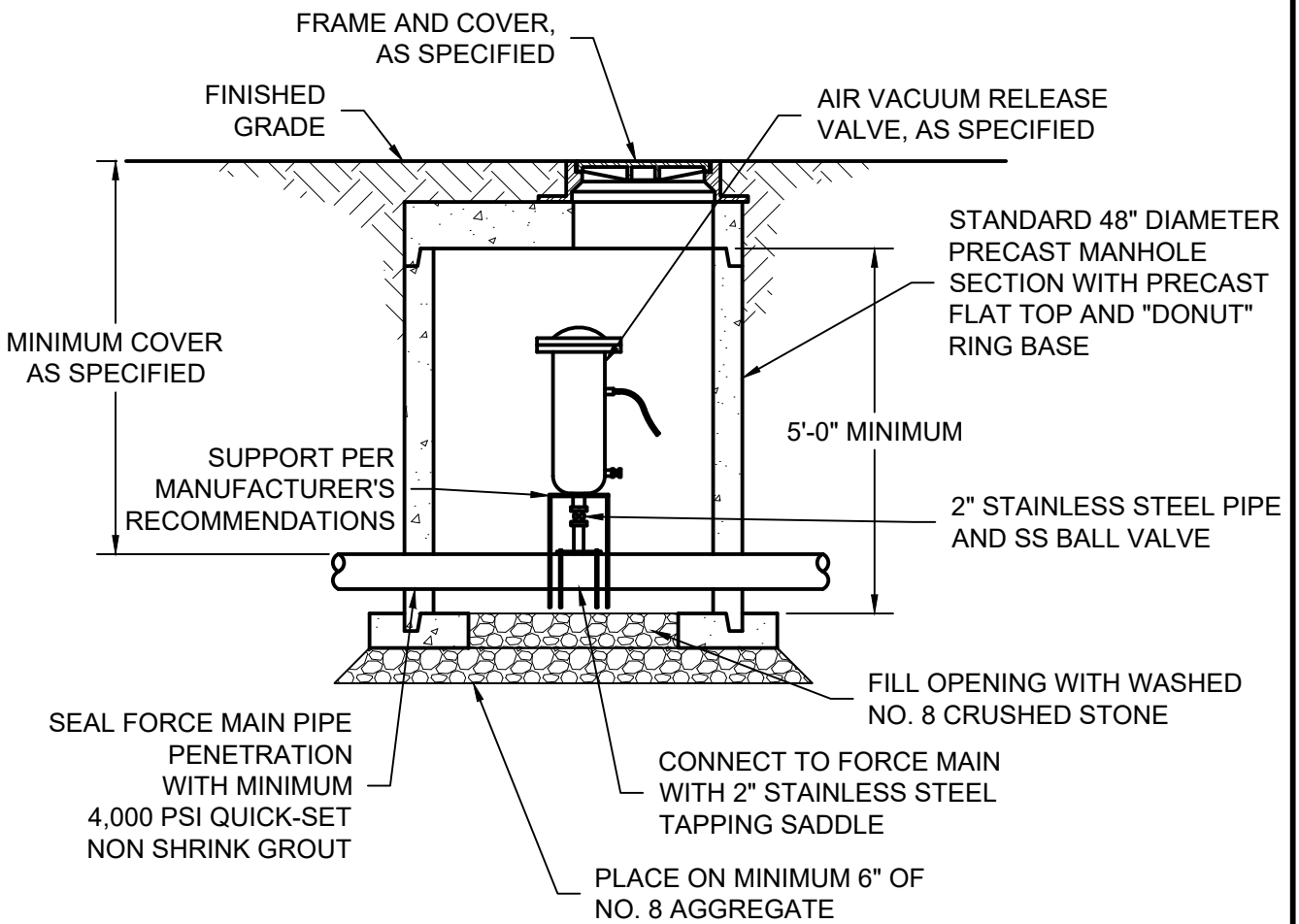

NOTES:

1. THE CONTRACTOR SHALL DETERMINE THE REQUIRED FORCE MAIN DEPTH AT THE STRUCTURE TO ENSURE THAT THE VALVE VAULT STRUCTURE DOES NOT EXTEND ABOVE FINISHED GRADE.
2. LOCATION OF AIR/VACUUM RELEASE STRUCTURES ARE APPROXIMATE. THE FINAL LOCATION TO BE DETERMINED IN THE FIELD BY THE CONTRACTOR AT THE HIGH ELEVATION POINT OF THE FORCE MAIN.



AIR/VACUUM RELEASE VALVE

DETAIL NO. 5D
DATE: 9/11/2024

Drawing: J:\NrsStar Connect\Sheds Manuals\STANDARD DETAIL\SWW-02730-Std Sanitary Sewer Drop MH.dwg | Layout: 8.5x11 Std | Plotter: 01/22/25 @ 09:00:54 | LastSavedBy: MasonF

BUTYL RUBBER BASE EXTERIOR BACKPLASTER MATERIAL
1/4" MIN THICKNESS, FROM 2" BELOW BOTTOM ADJUSTING
RING TO COVERING THE BASE OF CASTING

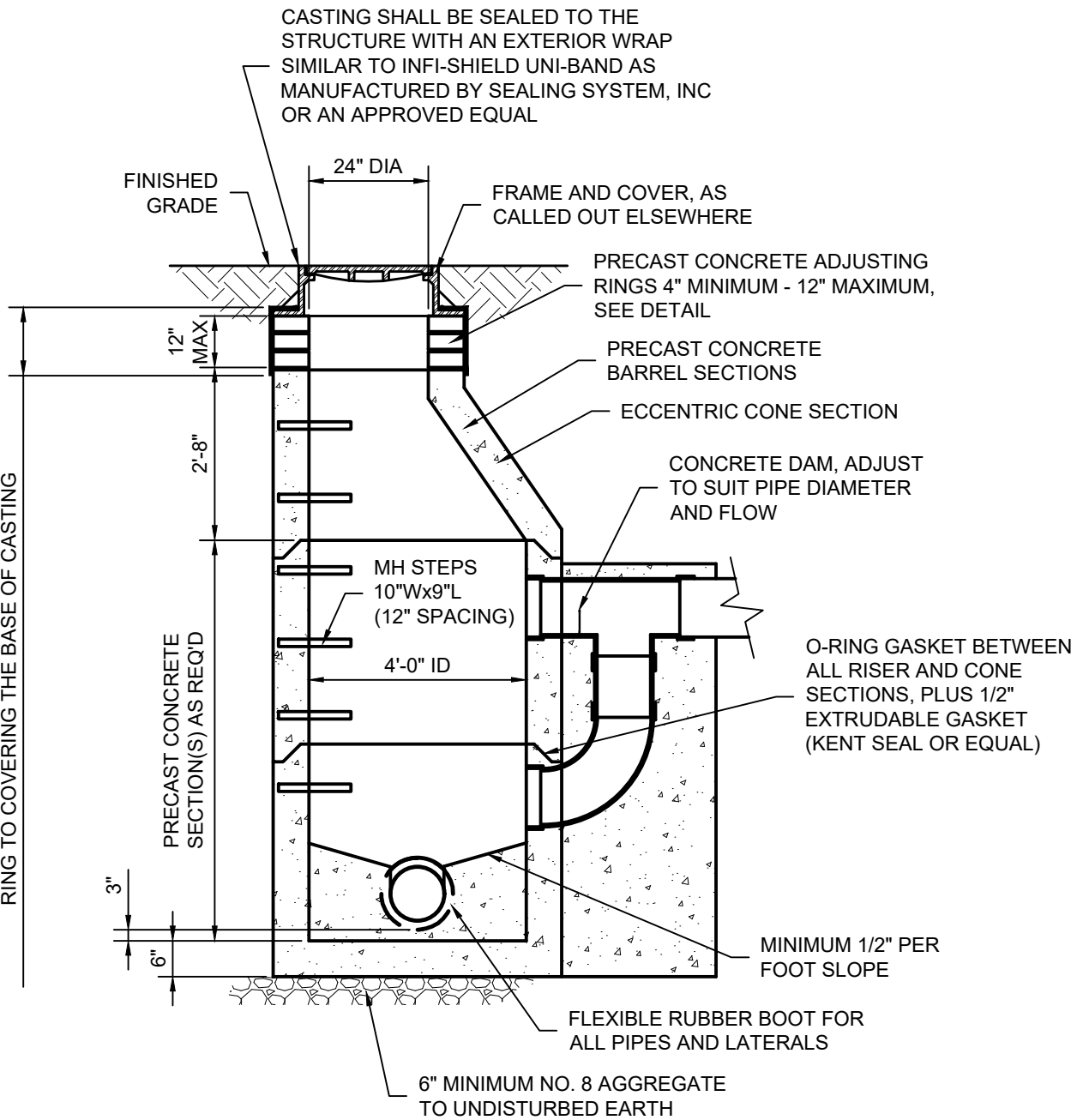

NOTE:

1. STEPS SHALL BE POLYPROPYLENE COATED STEEL REINFORCING, OR AN APPROVED NON-CORROSIVE FIBERGLASS MATERIAL. THE COPOLYMER POLYPROPYLENE SHALL MEET THE REQUIREMENTS OF ASTM D-4101 REINFORCED WITH DEFORMED 1/2 INCH MINIMUM DIAMETER REINFORCING STEEL CONFORMING TO THE REQUIREMENTS OF ASTM A-615, GRADE 60. NON-COATED CAST IRON STEPS ARE NOT ACCEPTABLE.
2. VERIFY WITH OWNER IF MANHOLE STEPS ARE REQUIRED.
3. PROVIDE ALL MANHOLES WITH COATING IN ACCORDANCE WITH STANDARDS.



STANDARD SANITARY SEWER DROP MH

DETAIL NO. 5F
DATE: 1/22/25

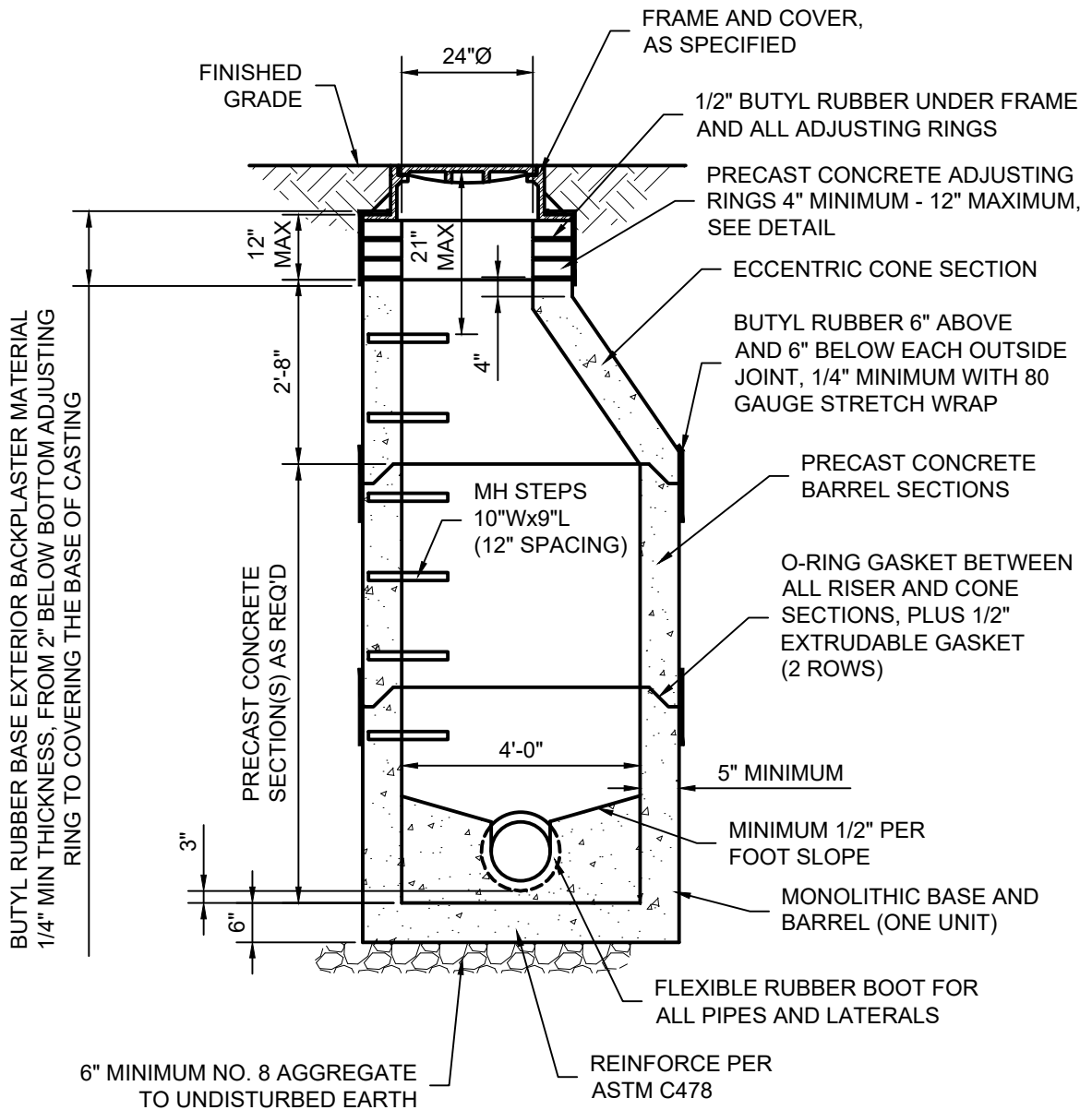

BUTYL RUBBER BASE EXTERIOR BACKPLASTER MATERIAL
1/4" MIN THICKNESS, FROM 2" BELOW BOTTOM ADJUSTING
RING TO COVERING THE BASE OF CASTING

NOTE:

1. STEPS SHALL BE POLYPROPYLENE COATED STEEL REINFORCING, OR AN APPROVED NON-CORROSIVE FIBERGLASS MATERIAL. THE COPOLYMER POLYPROPYLENE SHALL MEET THE REQUIREMENTS OF ASTM D-4101 REINFORCED WITH DEFORMED 1/2 INCH MINIMUM DIAMETER REINFORCING STEEL CONFORMING TO THE REQUIREMENTS OF ASTM A-615, GRADE 60. NON-COATED CAST IRON STEPS ARE NOT ACCEPTABLE.
2. VERIFY WITH OWNER IF MANHOLE STEPS ARE REQUIRED.
3. PROVIDE ALL MANHOLES WITH COATING IN ACCORDANCE WITH STANDARDS.



STANDARD SANITARY SEWER MH

DETAIL NO. 5E
DATE: 1/22/2025

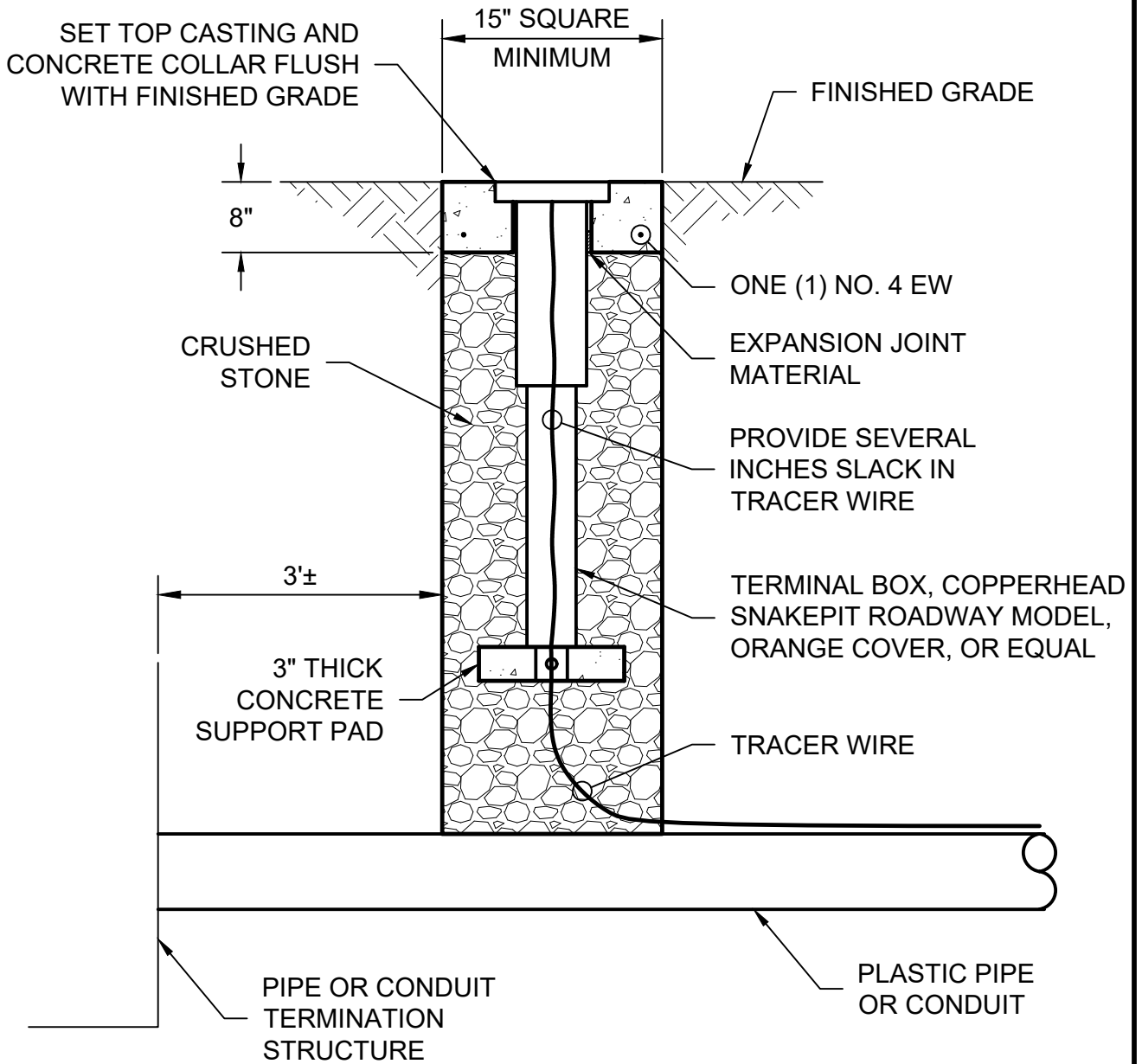

NOTES:

1. CONCRETE COLLAR NOT REQUIRED IF LOCATED IN PAVEMENT.



TRACER WIRE TERMINAL BOX DETAIL

DETAIL NO. 5G
DATE: 9/11/2024

PIPE SIZE	8" TO 16"	18" TO 30"	33" AND OVER
BEDDING BELOW THE PIPE BARREL	4"	OD / 4	8"

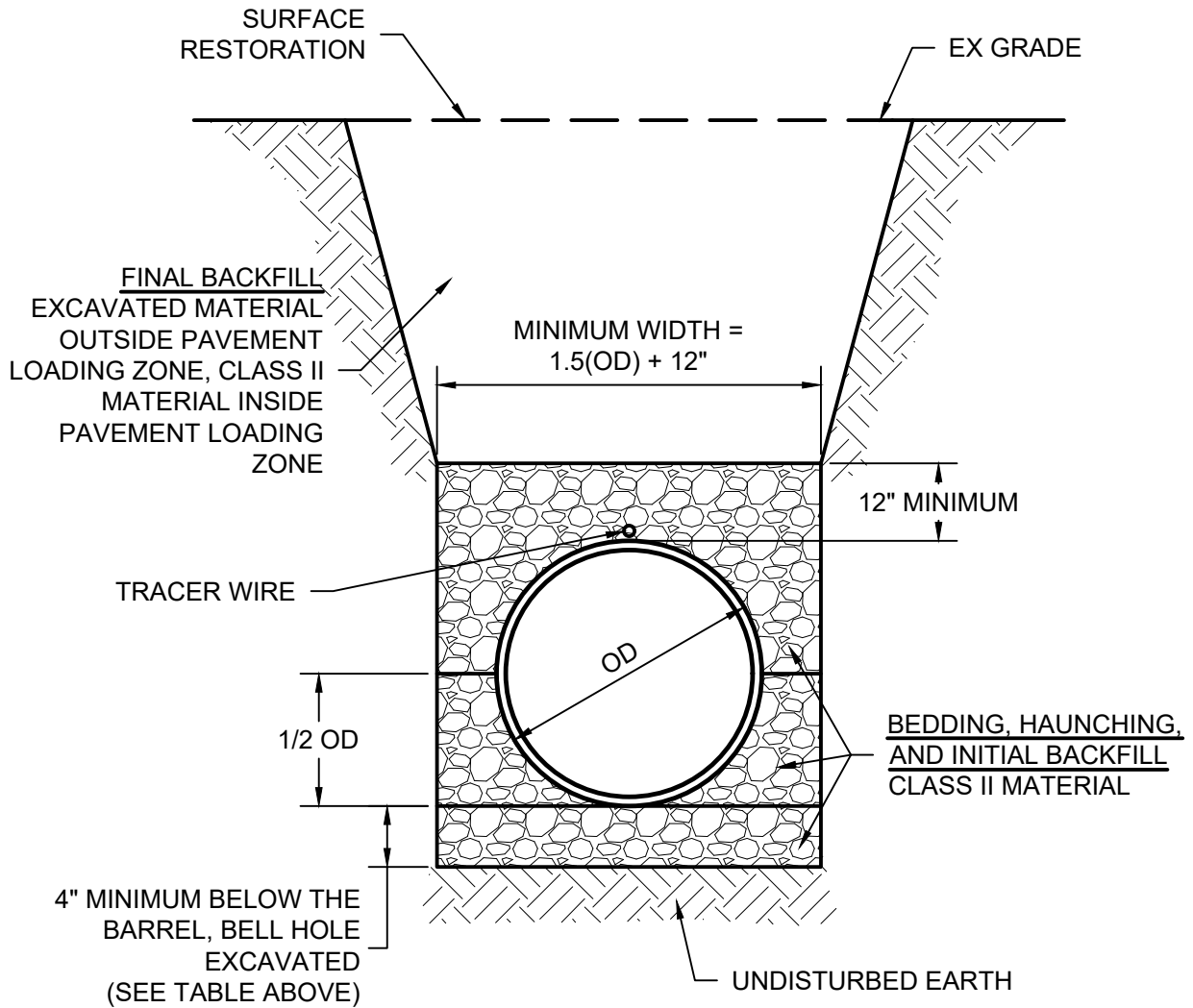

Drawing: J:\Nrs\Star Connect\Sheds Manuals\STANDARD DETAIL\STB-02220-Plastic-Gravity.dwg | Layout: 8.5x11 Std | Plotted: 01/22/25 @ 09:03:34 | LastSavedBy: MasonF



FLEXIBLE PIPE TRENCH (GRAVITY)

DETAIL NO. 5H
DATE: 1/22/2025

PIPE SIZE	3" TO 15"	18" TO 30"
BEDDING BELOW THE PIPE BARREL	4"	OD / 4

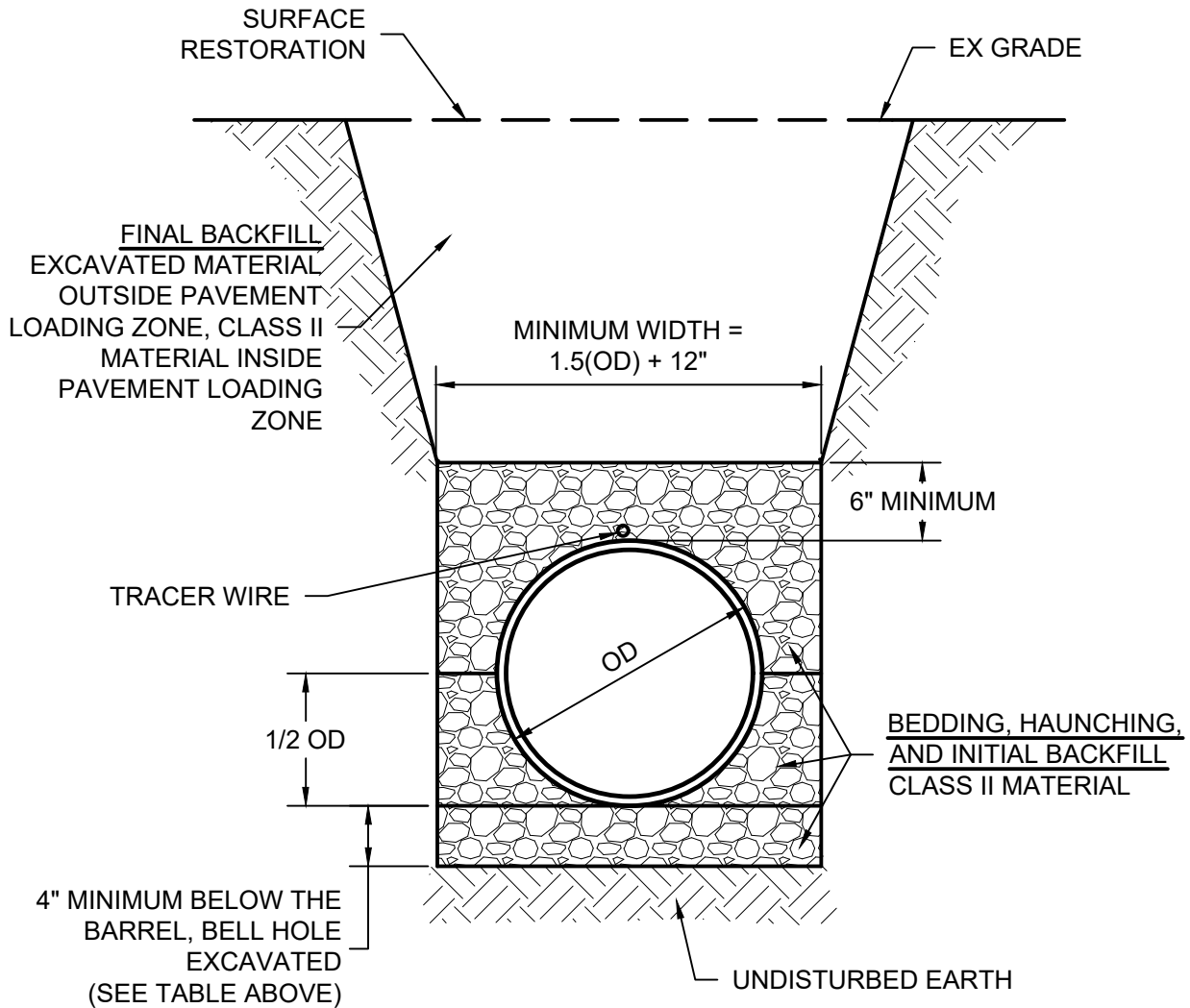

FLEXIBLE (HDPE, PP, PVC) PIPE TRENCH

SCALE: NONE



FLEXIBLE PIPE TRENCH (PRESSURE)

DETAIL NO. 51
DATE: 1/22/2025

Drawing: C:\Users\mason\OneDrive - Wessler Engineering\Inc\Desktop\NEW\INESTAR DETAILS (AUGUST 2024)\WW-02730-Service Connect-Deep.dwg | Layout: 8.5x11 Std | Plotted: 09/11/24 @ 11:03:47 | LastSavedBy: MasonF

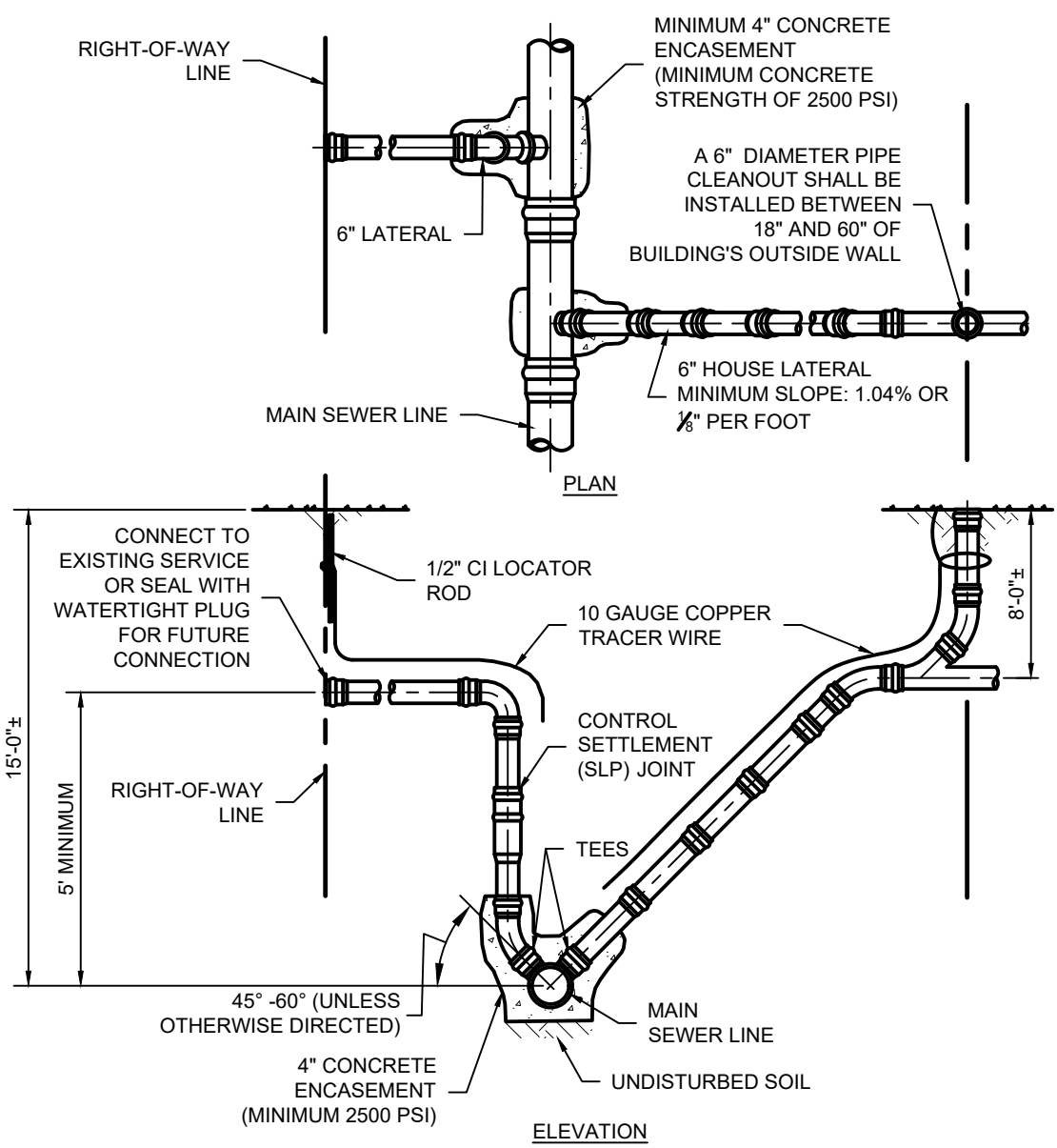

- NOTES:**
- SANITARY LATERALS SHALL BE INSTALLED WHERE INDICATED. THEY SHALL BE EXTENDED TO RIGHT-OF-WAY LINES OR TO DISTANCES AS SHOWN ON THE DRAWINGS, AND SHALL BE 6" PIPE UNLESS OTHERWISE SHOWN.
 - THE DEPTH OF THE LATERAL AT THE PROPERTY LINE SHALL BE APPROXIMATELY 8'-0" UNLESS SEWER DEPTH IS LESS, A MINIMUM SLOPE OF 1/8" PER 1'-0" SHALL BE USED.



SAN LATERAL 15' DEEP AND OVER

DETAIL NO. 5K
DATE: 9/11/24

Drawing: C:\Users\mason\OneDrive - Wessler Engineering\Incl\Desktop\NEW\WINESTAR DETAILS (AUGUST 2024)\WW-02730-Service Connect-Shallow.dwg | Layout: 5.5x11 Std | Plotted: 09/11/24 @ 11:04:54 | LastSavedBy: MasonF

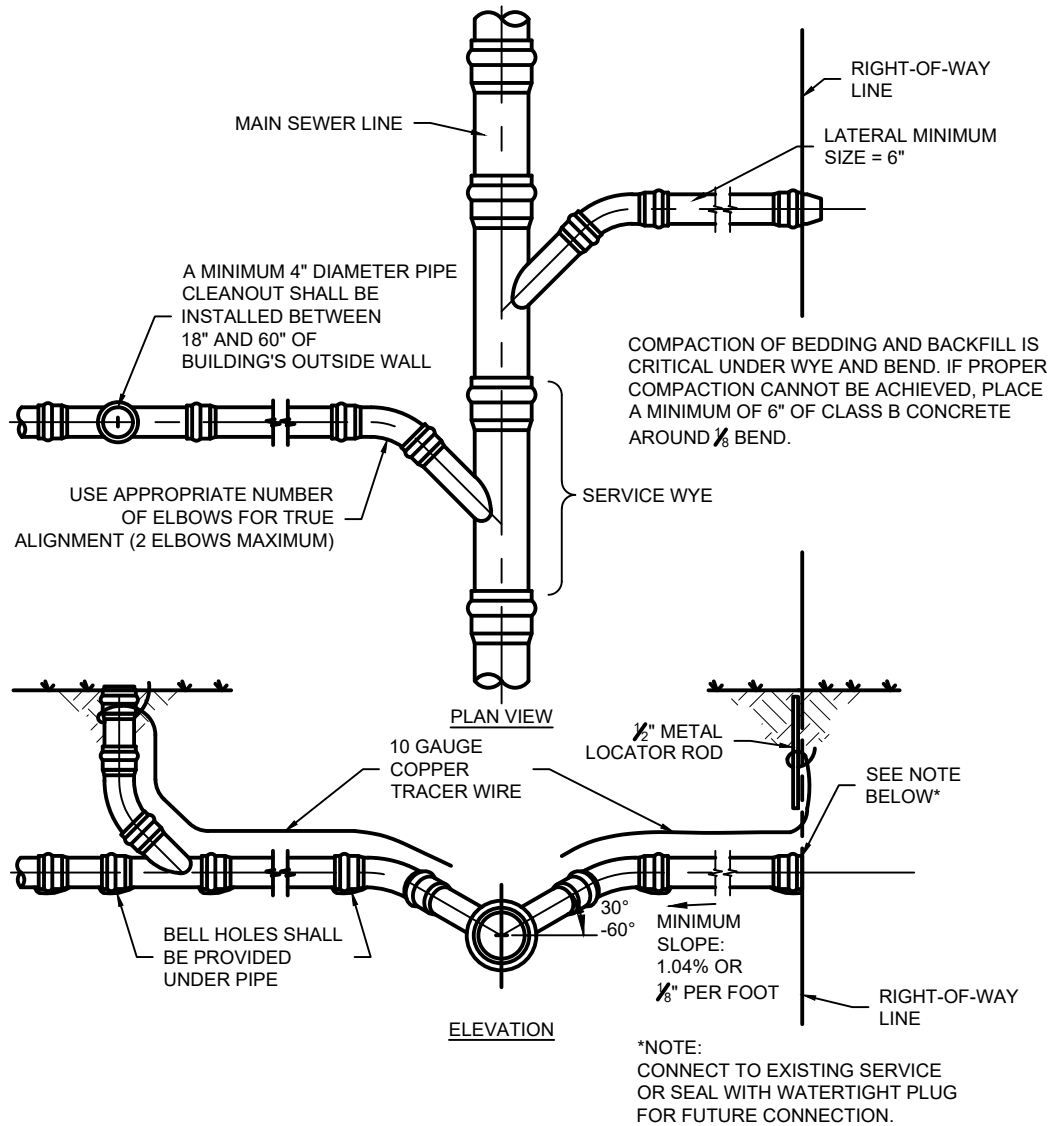

NOTES:

1. WYE BRANCHES SHALL BE INSTALLED WHERE INDICATED. THEY SHALL BE EXTENDED TO PROPERTY LINES OR TO DISTANCES AS SHOWN ON THE DRAWINGS, AND SHALL BE OF 6" PIPE UNLESS OTHERWISE SHOWN.
2. THE DEPTH OF THE LATERAL AT THE PROPERTY LINE SHALL BE APPROXIMATELY 8'-0" UNLESS SEWER DEPTH IS LESS, IN WHICH EVENT A MINIMUM SLOPE OF 1/8" PER 1'-0" SHALL BE USED.



SAN LATERAL LESS THAN 15' DEEP

DETAIL NO. 5L
DATE: 9/11/24

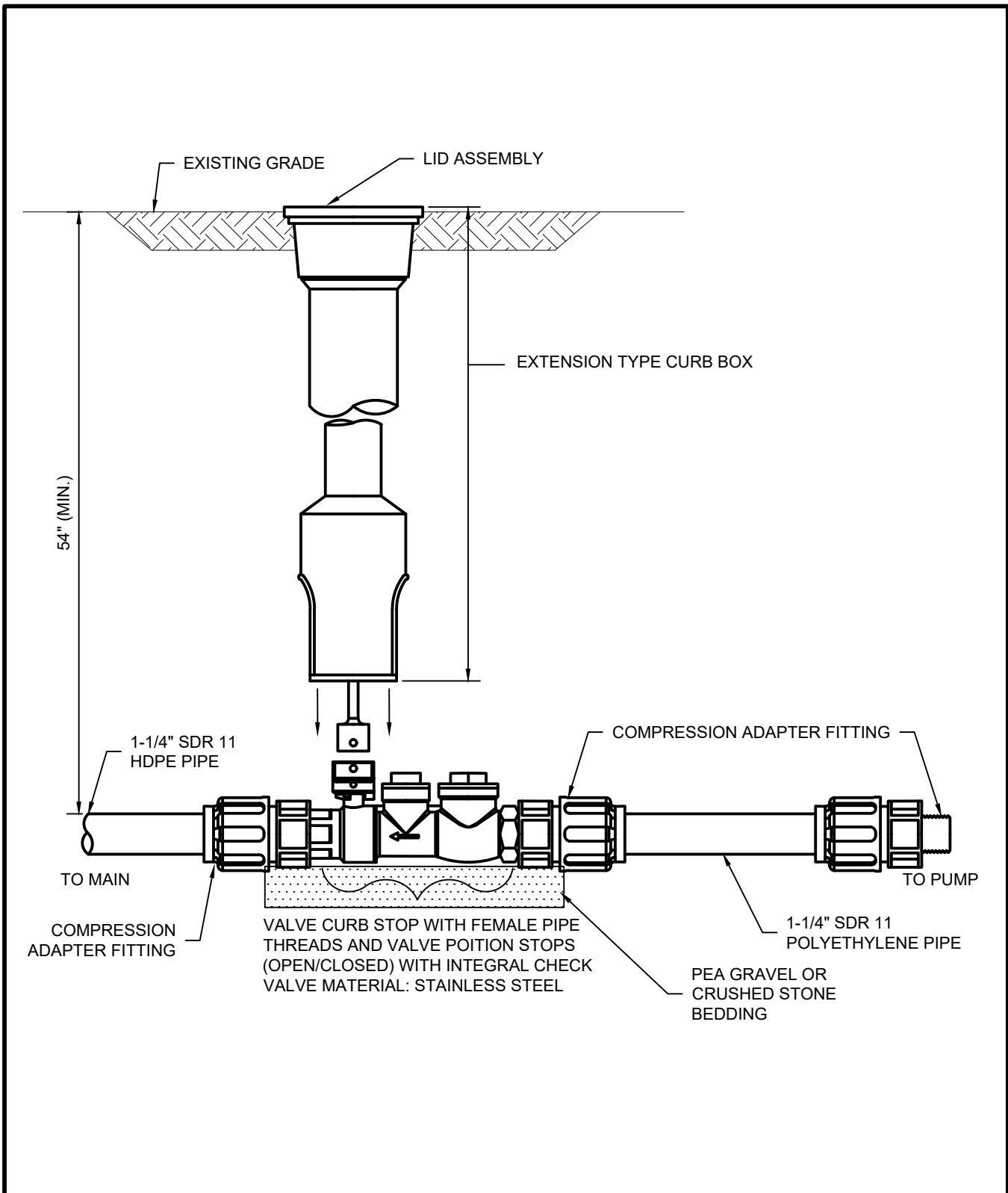

Drawing: C:\Users\mason\OneDrive - Wessler Engineering\Inc\Desktop\NEW\WINESTAR DETAILS (AUGUST 2024)\LATERAL DETAIL.dwg | Layout: 8.5x11 Std | Plotted: 09/11/24 @ 11:08:14 | LastSavedBy: MasonF

WESSLER
ENGINEERING
More than a Project™

LATERAL DETAIL (PRESSURE CONNECTION)

DETAIL NO. 5M
DATE: 9/11/2024

Drawing: C:\Users\masonr\OneDrive - Wessler Engineering\Inc\Desktop\NEW WINESTAR DETAILS\TYPICAL DUPLEX LIFT STATION PLAN.dwg | Layout: Std | Plotted: 09/11/24 @ 11:09:31 | LastSavedBy: MasonrF

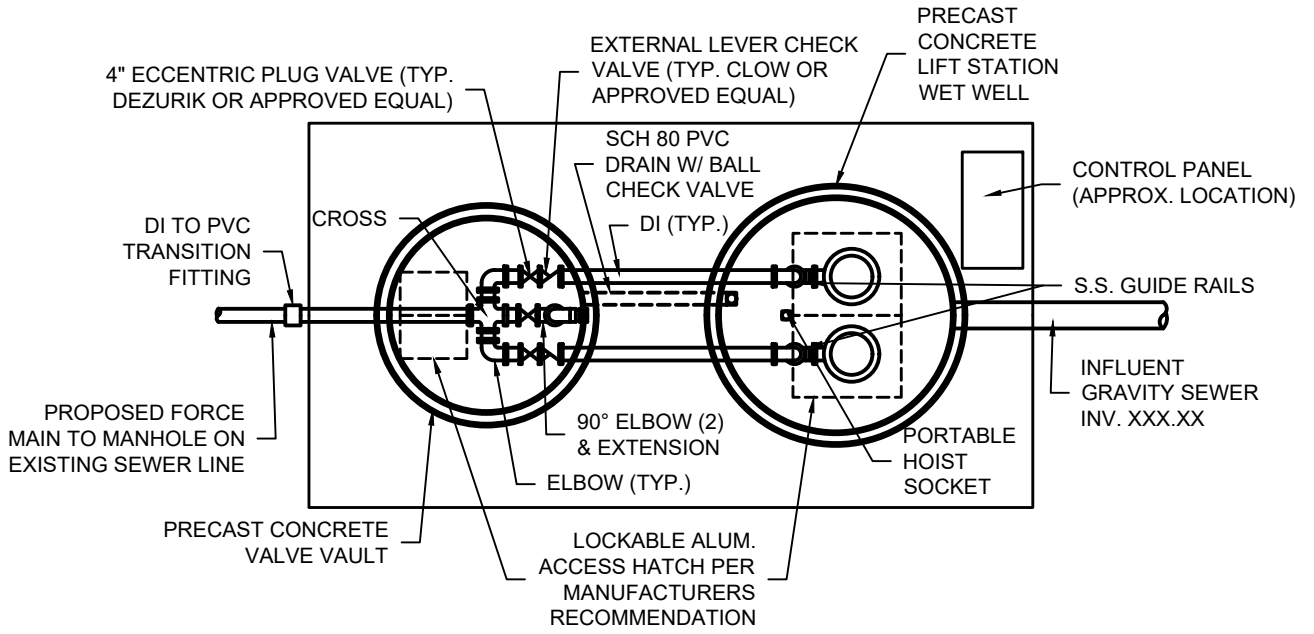

TYPICAL DUPLEX LIFT STATION PLAN

DETAIL NO. 6A
DATE: 9/11/2024

Drawing: C:\Users\mason\OneDrive - Wessler Engineering\Inc\Desktop\NEW WINESTAR DETAILS (AUGUST 2024)\TYPICAL DUPLEX LIFT STATION SECTION.dwg | Layout: Std1 | Plotter: 09/11/24 @ 11:10:12 | LastSavedBy: MasonF

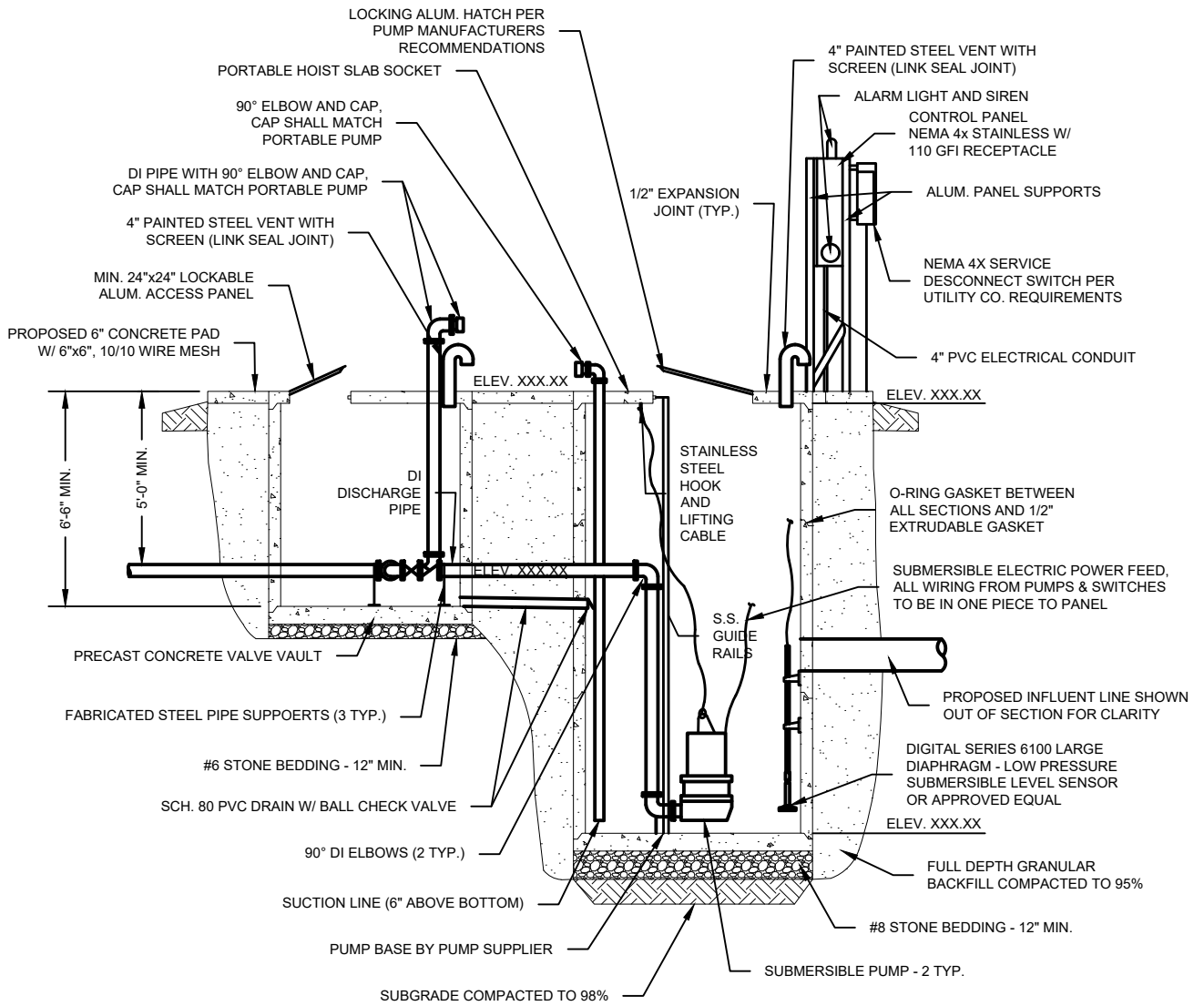

TYPICAL DUPLEX LIFT STATION SECTION

NOTE: DIMENSIONS TO BE DETERMINED BASED ON SPECIFIC APPLICATION



TYPICAL DUPLEX LIFT STATION SECTION

DETAIL NO. 6B
DATE: 9/10/2024

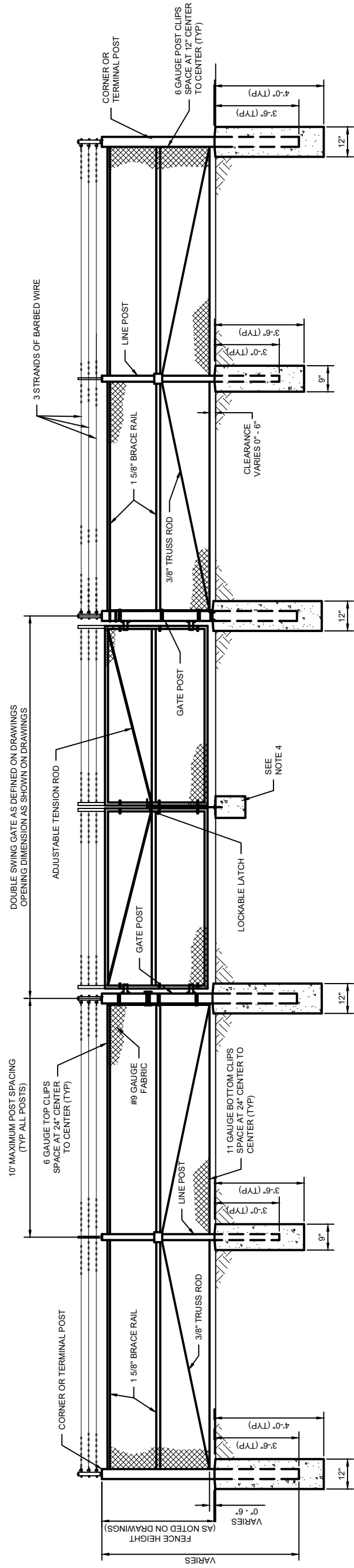

- NOTES:**
1. TERMINAL POSTS SHALL BE USED AT EACH FENCE CORNER OR END. GATE POSTS SHALL BE USED AT EACH GATE OPENING. LINE POSTS SHALL BE USED AT MAXIMUM 10' SPACING WHERE TERMINAL, GATE OR PULL POSTS ARE NOT REQUIRED.
 2. PULL POSTS SHALL BE SPACED AT A MAXIMUM OF 500' ON LONG STRAIGHT RUNS ALONG CONSISTENT GRADES; AT EVERY HORIZONTAL BEND GREATER THAN 10' WHERE TERMINAL POSTS ARE NOT REQUIRED, AND AT EVERY MAJOR CHANGE OF GRADE. PULL POSTS SHALL NOT BE USED AS GATE OR TERMINAL POSTS.
 3. ALL CONCRETE IN POST ANCHORS SHALL CONFORM TO THE SPECIFICATIONS.
 4. PROVIDE 8" X 8" X 12" DEEP CONCRETE BLOCKING FOR GATE LATCH.

DOUBLE GATE



CHAIN LINK FENCE INSTALLATION

DETAIL NO. 6C
DATE: 9/11/2024

Drawing: Y:\Wessler Groups\Card Users\Autocad Training\MTF\REVISED DETAIL SHEETS\NEW NINESTAR DETAILS (AUGUST 2024)\AIR RELEASE VALVE.dwg | Layout: 8.5x11 Std | Plotted: 11/25/2024 @ 08:23:31 | LastSavedBy: Mascif

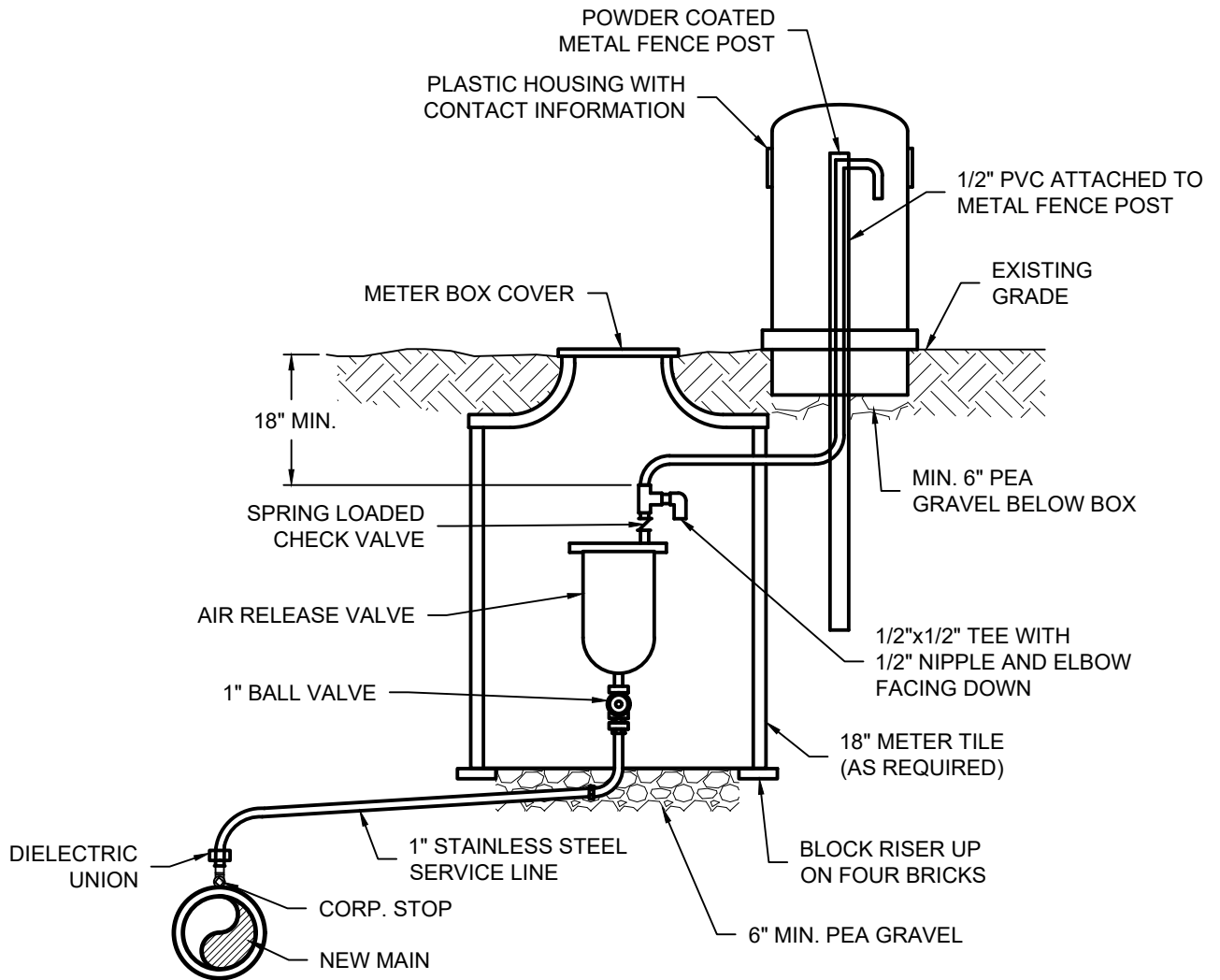

WATER LINE AIR RELEASE VALVE

DETAIL NO. 7A
DATE: 11/25/2024

Drawing: Y:\Wessler Groups\Cad Users\Autocad Training\MTF\REVISED DETAIL SHEETS\NEW NINESTAR DETAILS (AUGUST 2024)\GATE VALVE BOX & COVER OUT PAVEMENT.dwg | Layout: 8.5x11 Std | Potted: 11/25/24 @ 08:25:30 | LastSavedBy: MasonF

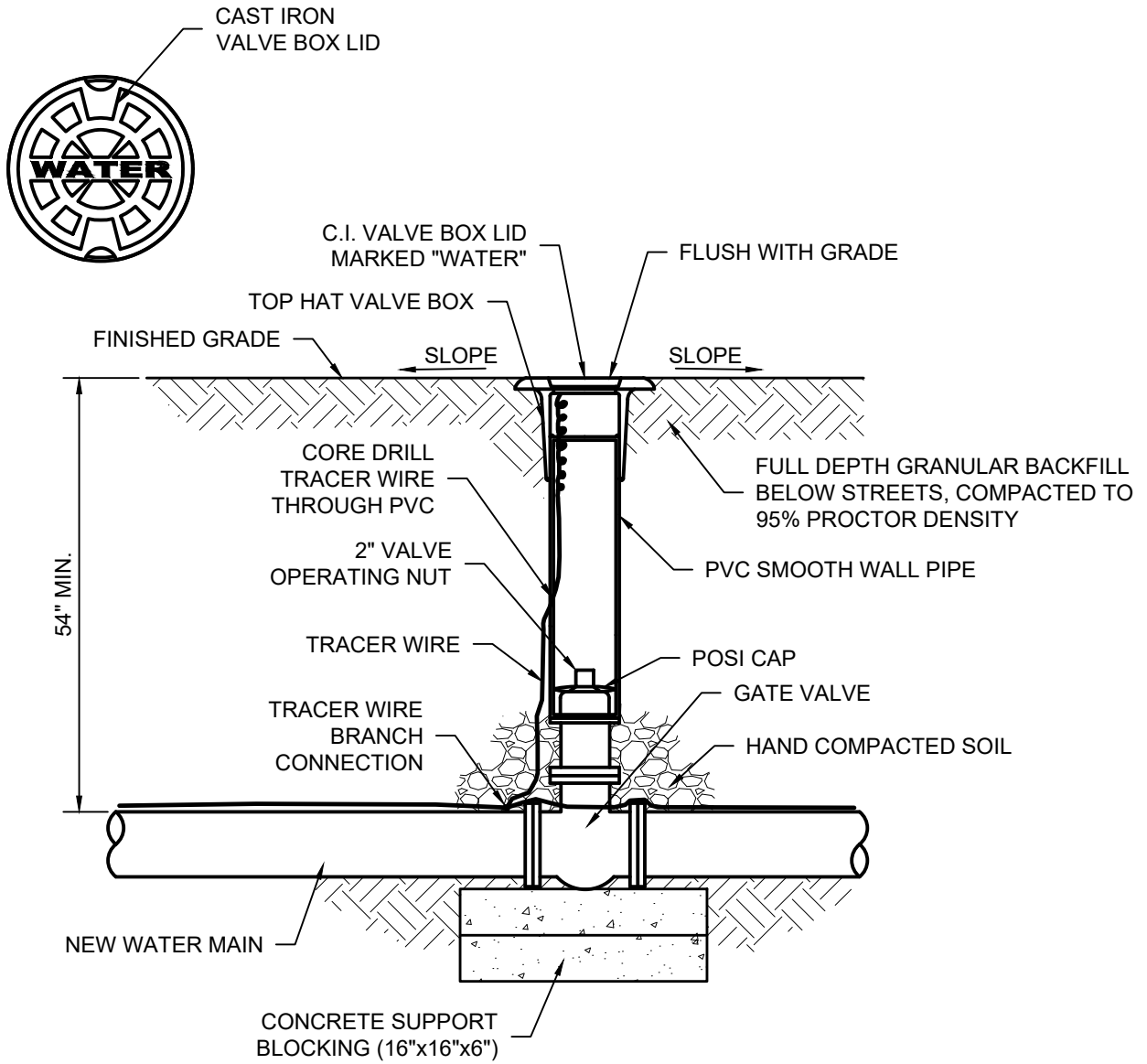

GATE VALVE BOX & COVER OUTSIDE PAVEMENT

DETAIL NO. 7B
DATE: 11/25/2024

Drawing: Y:\Wessler Groups\Cad Users\Autocad Training\MTF\REVISED DETAIL SHEETS\NEW NINESTAR DETAILS (AUGUST 2024)\GATE VALVE BOX & COVER IN PAVEMENT.dwg | Layout: 8.5x11 Std | Plotted: 11/25/24 @ 08:35:05 | LastSavedBy: MasonF

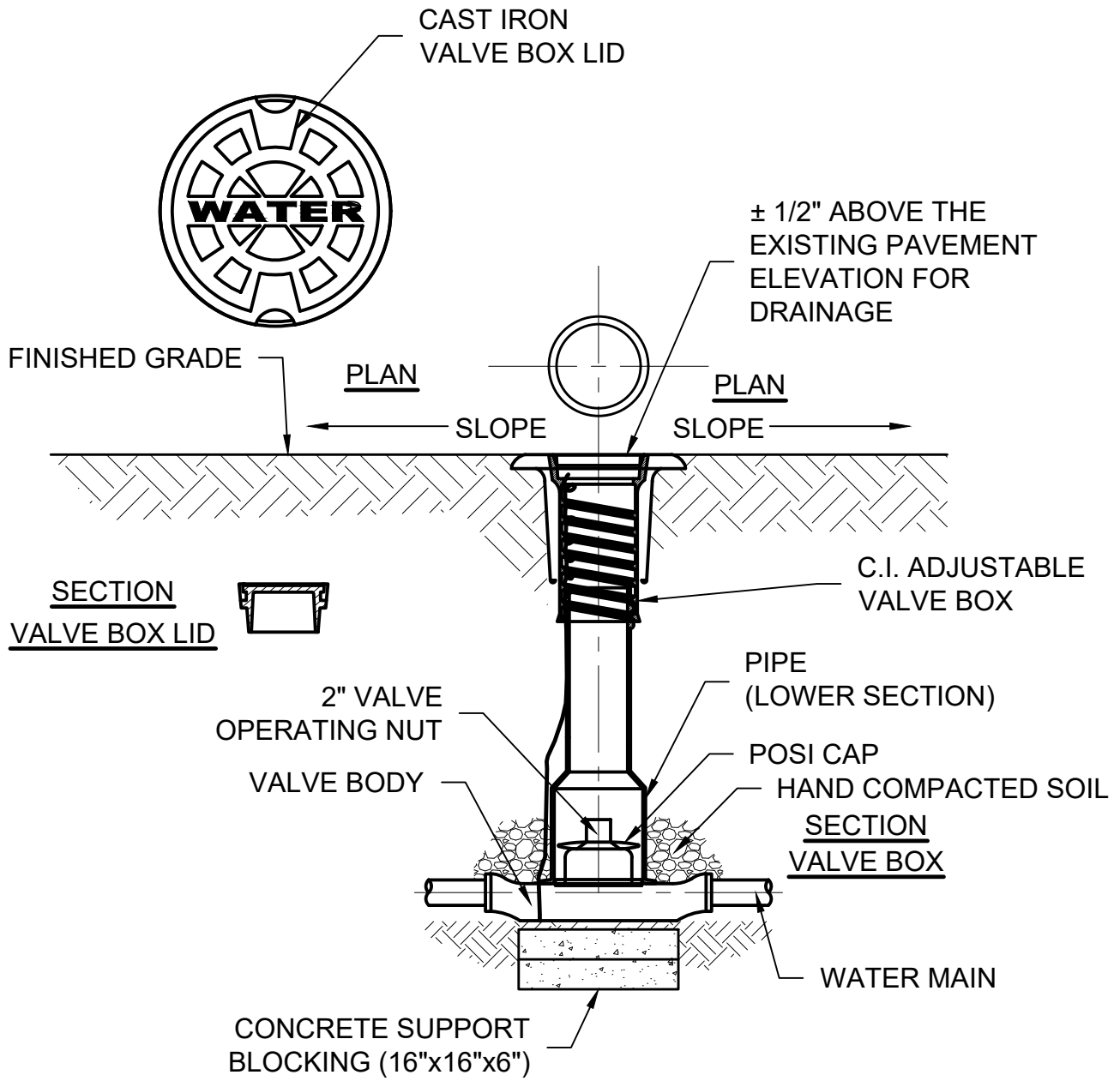

GATE VALVE BOX & COVER INSIDE PAVEMENT

DETAIL NO. 7C
DATE: 11/25/2024

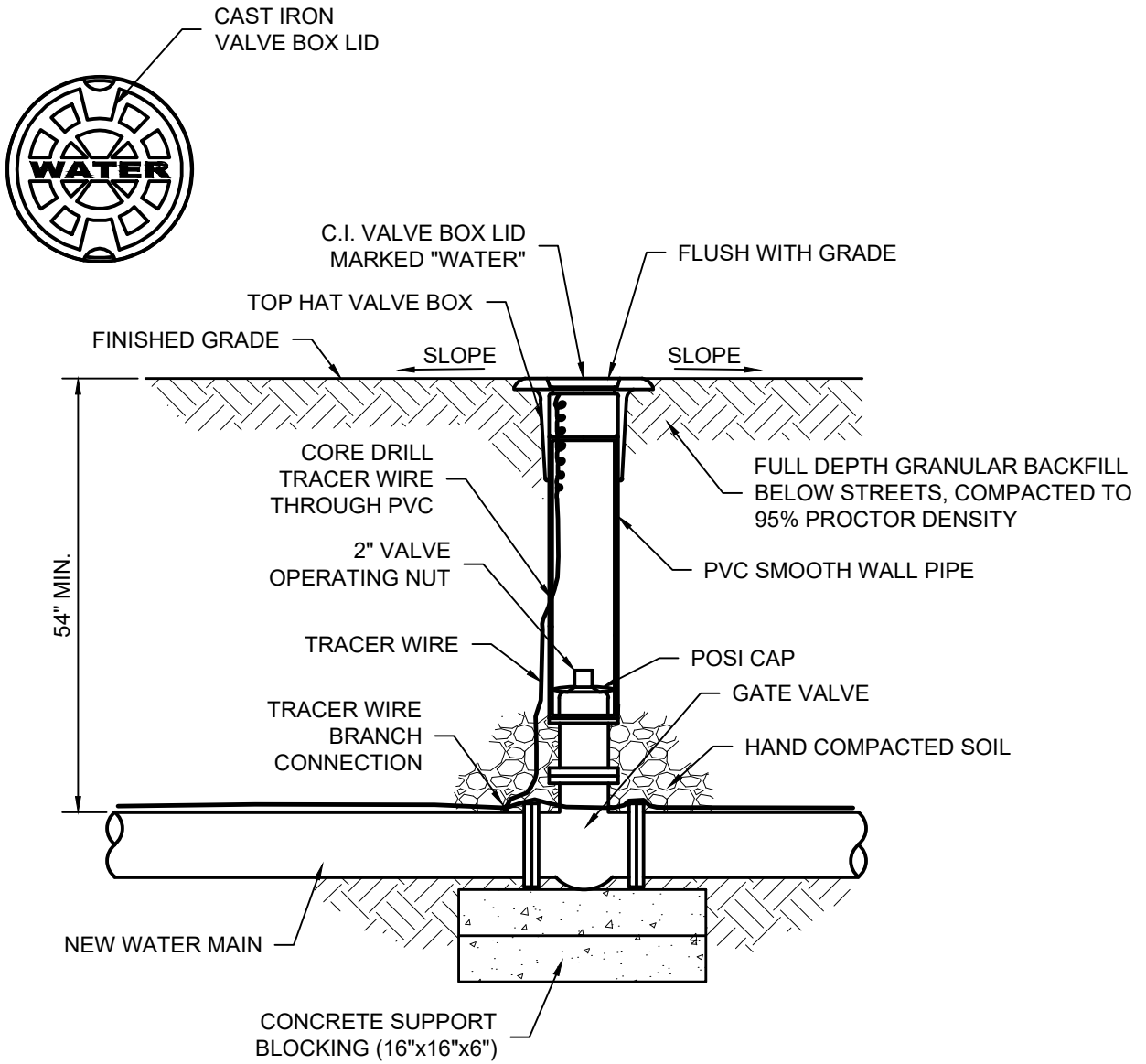

GATE VALVE AND COVER OUTSIDE PAVEMENT

SCALE: NONE



GATE VALVE BOX & COVER OUTSIDE PAVEMENT

DETAIL NO. 7B
DATE: 1/22/2025

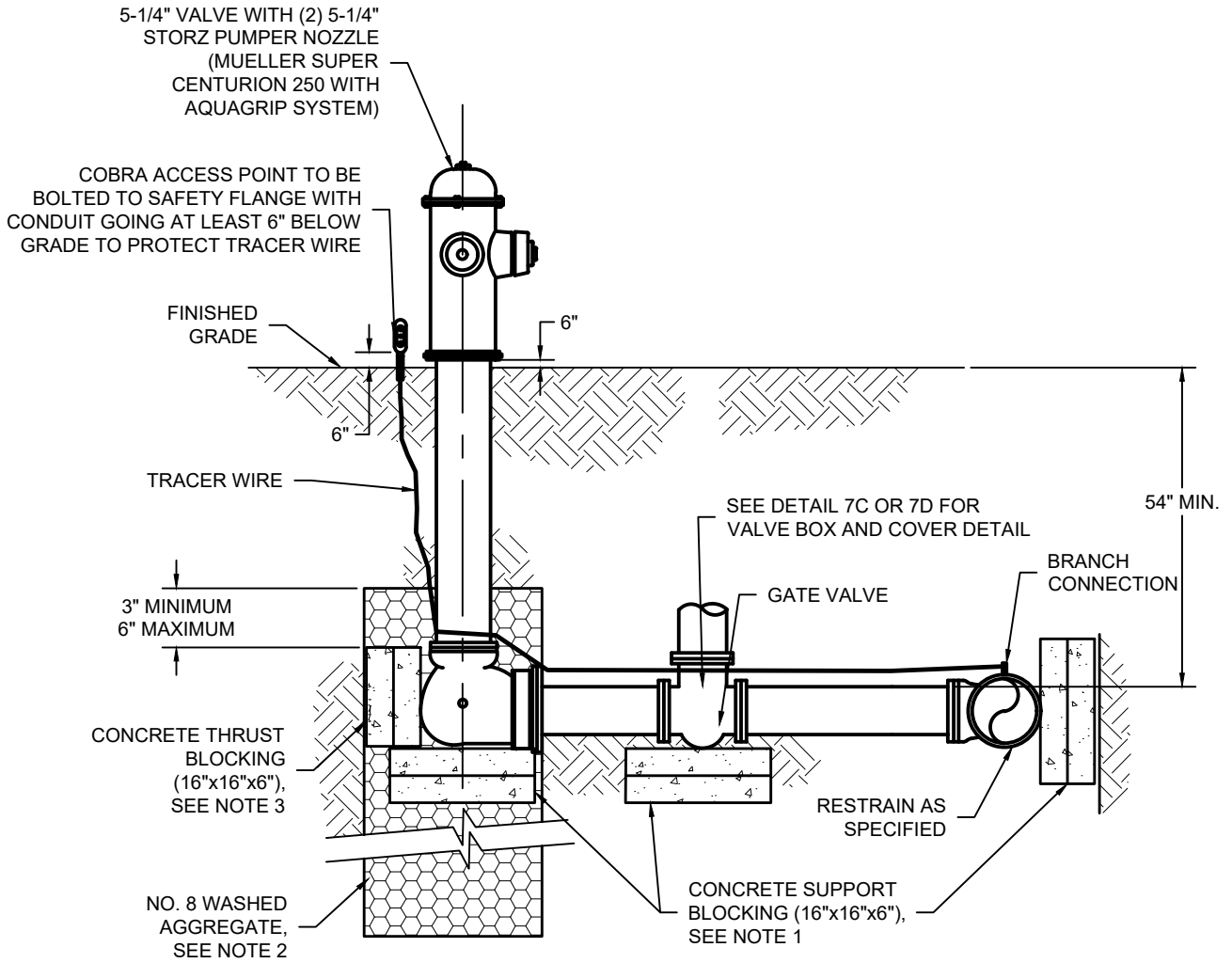

NOTES:

1. SET HYDRANT AND VALVE ON CONCRETE SUPPORT BLOCKING.
2. PLACE 2'x3' DEEP DRAINAGE PIT. EXTEND A MINIMUM OF 3", AND MAXIMUM OF 6", ABOVE HYDRANT BOOT.
3. RESTRAINED FITTINGS SHALL BE USED IN ADDITION TO CONCRETE THRUST BLOCKING. RESTRAINTS MUST BE USED FROM THE DISTRIBUTION MAIN TO THE HYDRANT. PLACE CONCRETE BLOCKS BEHIND HYDRANT TO UNDISTURBED EARTH.
4. VALVE BOX SHALL BE CENTERED AND PLUMB OVER VALVE OPERATING NUT USING POSI CAP.

H-3 HYDRANT ASSEMBLY

SCALE: NONE



HYDRANT ASSEMBLY

DETAIL NO. 7D
DATE: 1/22/2025

Drawing: C:\Users\mason\OneDrive - Wessler Engineering\Inc\Desktop\NEW\WINESTAR DETAILS (AUGUST 2024)\STANDARD HYDRANT BLOW OFF BLEED.dwg | Layout: 8.5x11 Std | Plotted: 09/11/24 @ 11:57:13 | LastSavedBy: MasonF

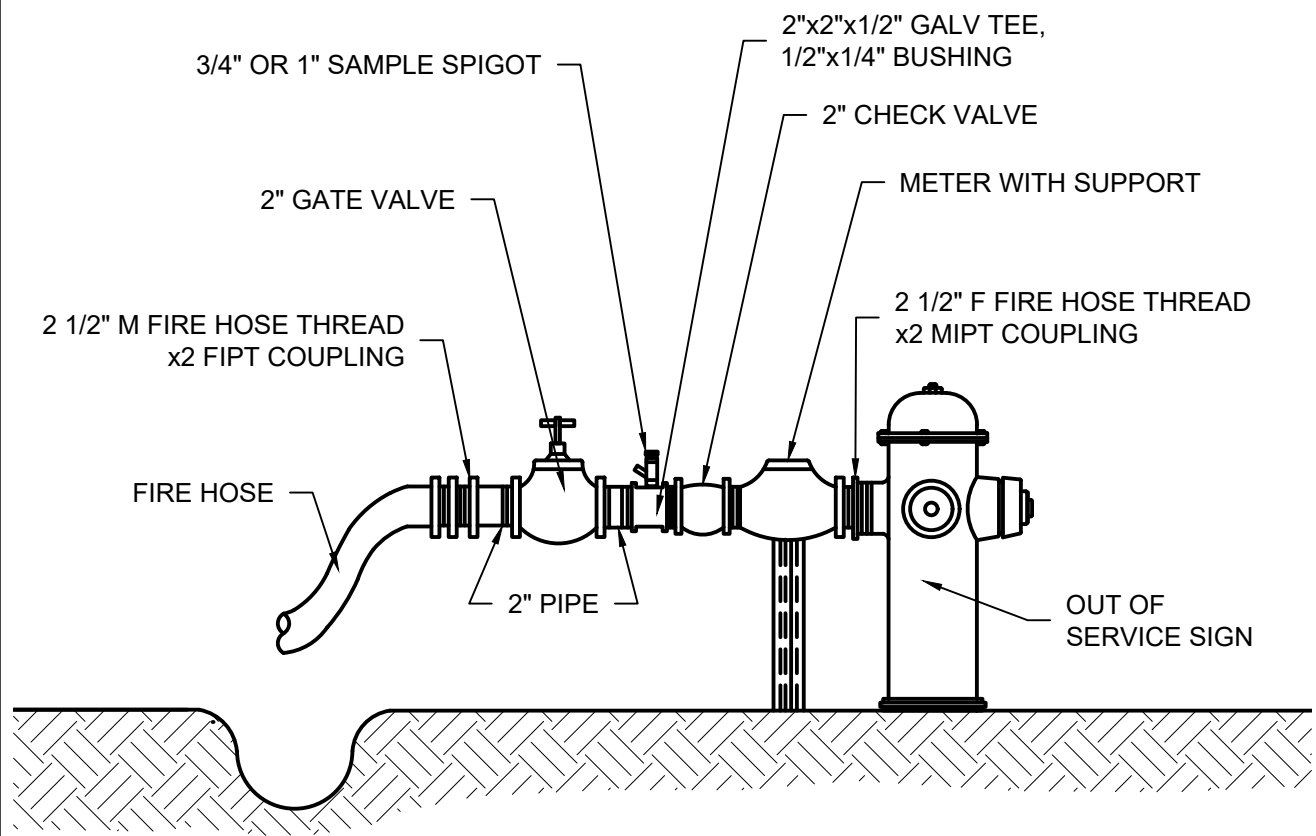

STANDARD HYDRANT/BLOW OFF BLEED

DETAIL NO. 7E
DATE: 9/11/2024

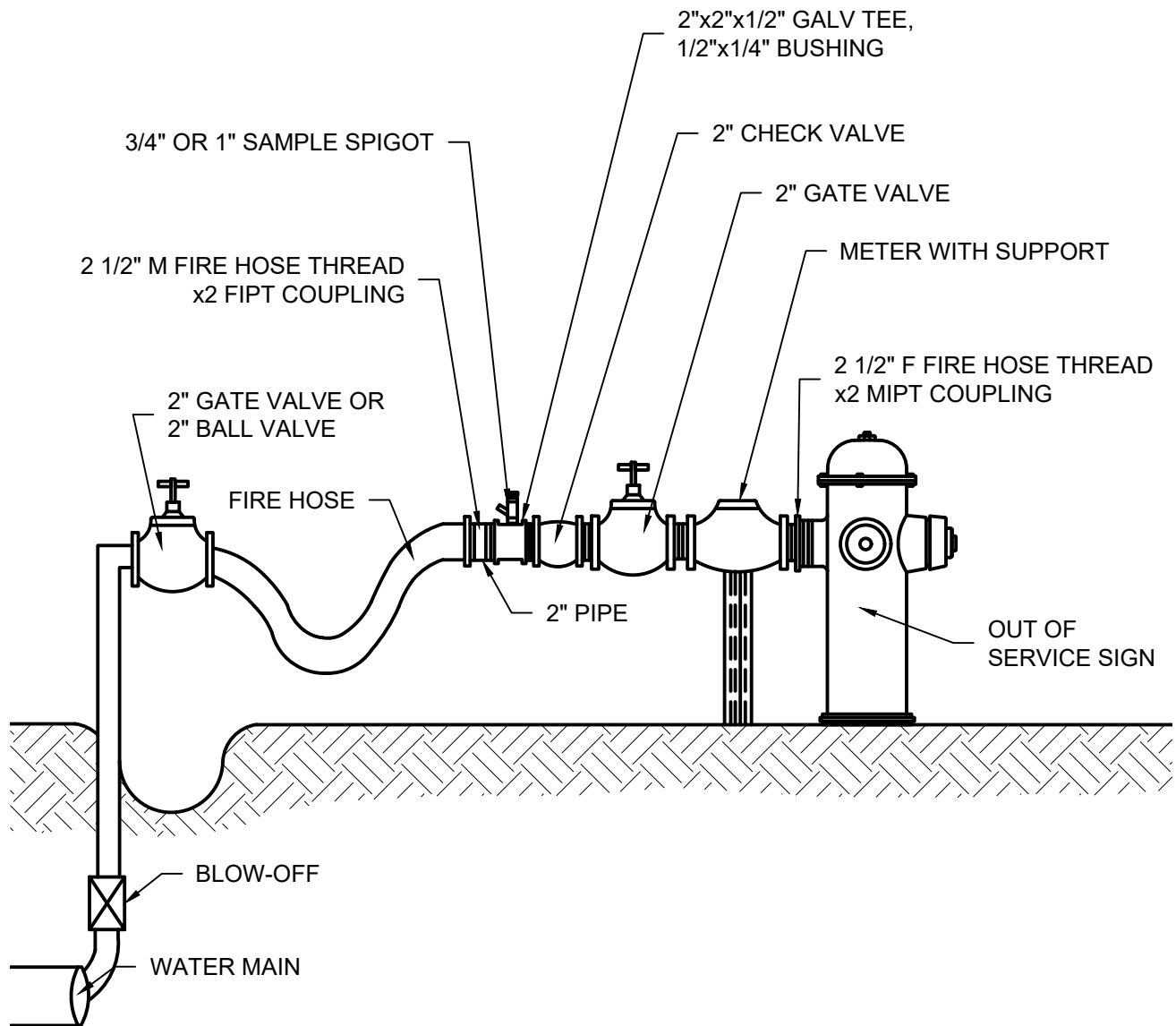

Drawing: C:\Users\masonr\OneDrive - Wessler Engineering\Inc\Desktop\NEW WINESTAR DETAILS (AUGUST 2024)\STANDARD HYDRANT TO BLOW OFF BLEED.dwg | Layout: 8.5x11 Std | Plotted: 09/11/24 @ 12:00:34 | LastSavedBy: MasonrF



STANDARD HYDRANT TO BLOW OFF BLEED

DETAIL NO. 7F
DATE: 9/11/2024

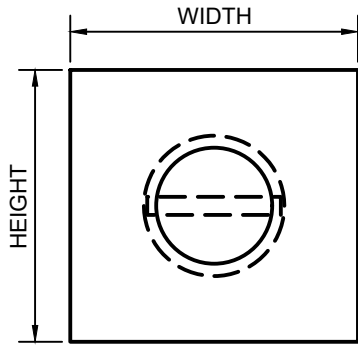

SECTION A

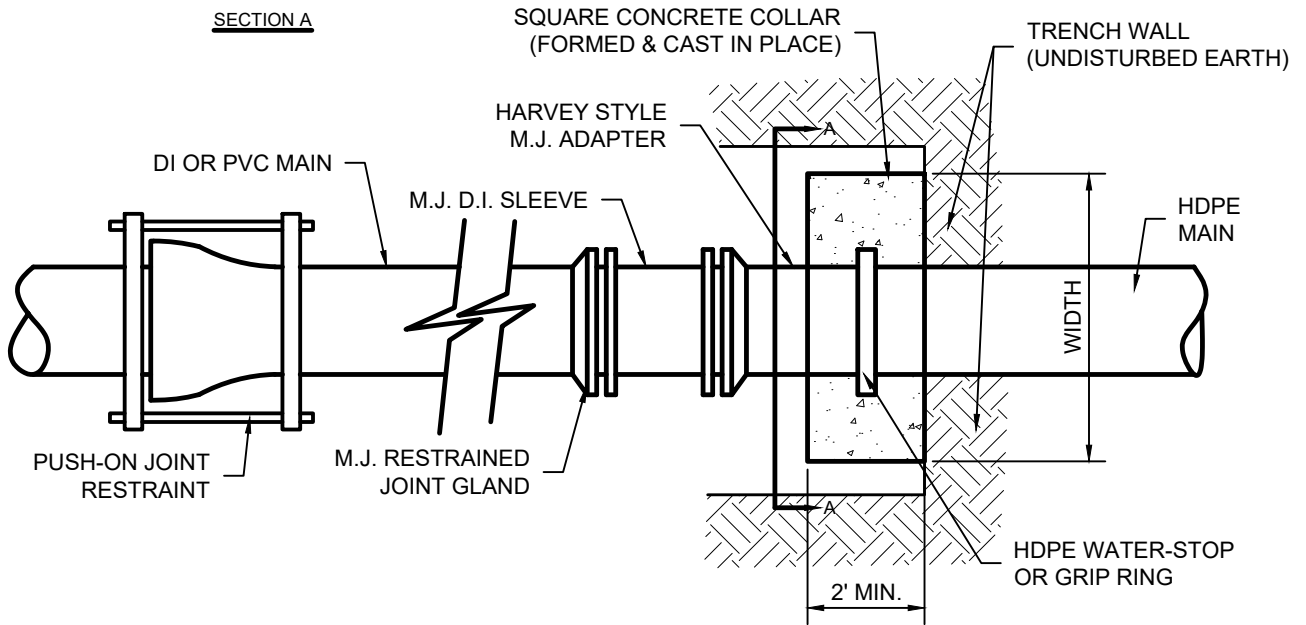

PIPE SIZE	WIDTH MINIMUM	HEIGHT MINIMUM	BRACING AREA OF CONCRETE COLLAR
6"	3'-0"	3'-0"	9 SQ. FT.
8"	3'-0"	3'-0"	9 SQ. FT.
10"	4'-0"	3'-6"	14 SQ. FT.
12"	4'-6"	4'-0"	18 SQ. FT.
16"	5'-0"	4'-0"	20 SQ. FT.
18"	5'-0"	4'-6"	25 SQ. FT.
20"	5'-0"	5'-0"	25 SQ. FT.

Drawing: C:\Users\mason\OneDrive - Wessler Engineering\Inc\Desktop\NEW\WINESTAR DETAILS (AUGUST 2024)\HDPE PIPE TRANSITION.dwg | Layout: 8.5x11 Std | Plotter: 09/11/24 @ 12:05:12 | LastSavedBy: MasonF



HDPE PIPE TRANSITION

DETAIL NO. 7G
DATE: 9/11/2024

Drawing: C:\Users\mason\OneDrive - Wessler Engineering\Inc\Desktop\NEW WINESTAR DETAILS (AUGUST 2024)\HDPE FITTING TRANSITION.dwg | Layout: 8.5x11 Std | Plotter: 09/11/24 @ 12:04:25 | LastSavedBy: Mason F

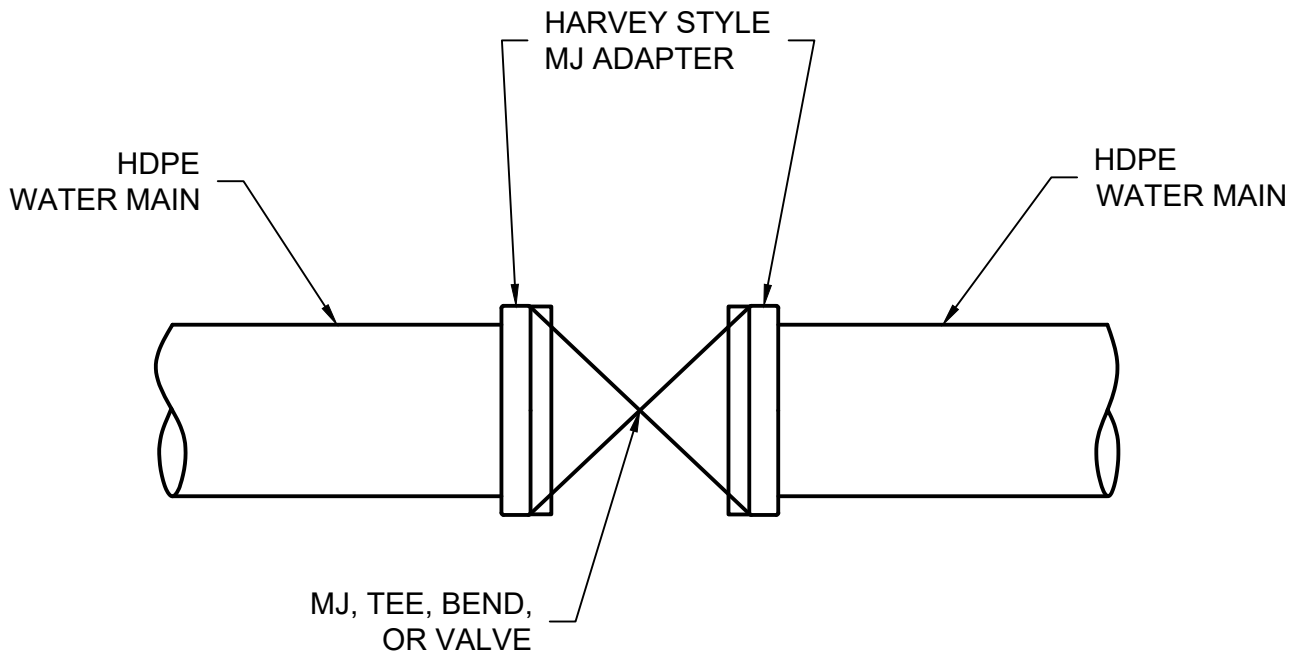

HDPE FITTING TRANSITION

DETAIL NO. 7H
DATE: 9/11/2024

Drawing: Y:\Wessler Groups\Card Users\Autocad Training\MTF-REVISED DETAIL SHEETS\NEW NINESTAR DETAILS (AUGUST 2024)\WATER METER AND SERVICE LINE.dwg | Layout: 8.5x11 Std | Plotted: 11/25/24 @ 08:39:52 | LastSavedBy: MasonF

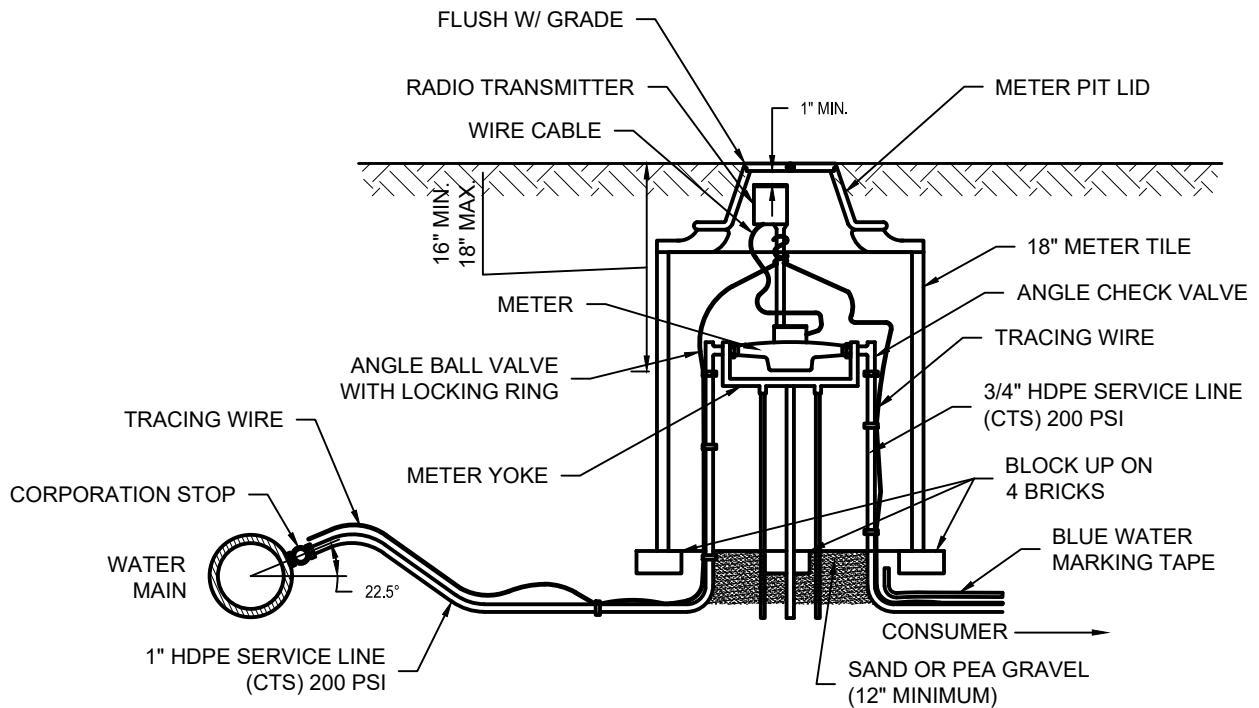

NOTES:

1. METER AND TRANSMITTER FURNISHED AND SET BY NINESTAR CONNECT.
2. ALL SERVICE LINES MUST HAVE 4-1/2' COVER REGARDLESS OF THE WATER MAIN DEPTH.
3. CENTER OF PROPERTY 5 FEET BEHIND SIDEWALK, 5 FEET FROM DRIVEWAY.
4. DO NOT LOCATE PIT IN DRIVEWAYS.
5. DO NOT BACKFILL THE SERVICE LINE TO THE CONSUMER UNTIL IT HAS BEEN INSPECTED.
6. THE TEN-FOOT SEPARATION BETWEEN WATER AND SEWER MUST BE MAINTAINED.
7. FINAL GRADE MUST BE ESTABLISHED PRIOR TO INSTALLATION OF METER PIT AND SERVICE LINE.
8. ALL LIVE TAPS TO BE COMPLETED BY A CERTIFIED CONTRACTOR.
9. NO SPLICES ALLOWED BETWEEN CORPORATION STOP AND ANGLE VALVE WITH LOCK WING.



WATER METER AND SERVICE LINE

DETAIL NO. 71
DATE: 11/25/2024

Drawing: J:\NineStar Connected\Projects\213119 NineStar Water USA\03-021 Water Constr. Sheds Update\Z CAD\Details\VAULT METERING DETAILS.dwg | Layout: 8.5x11 Std | Plotted: 10/07/25 @ 09:45:02 | LastSavedBy: JasonW

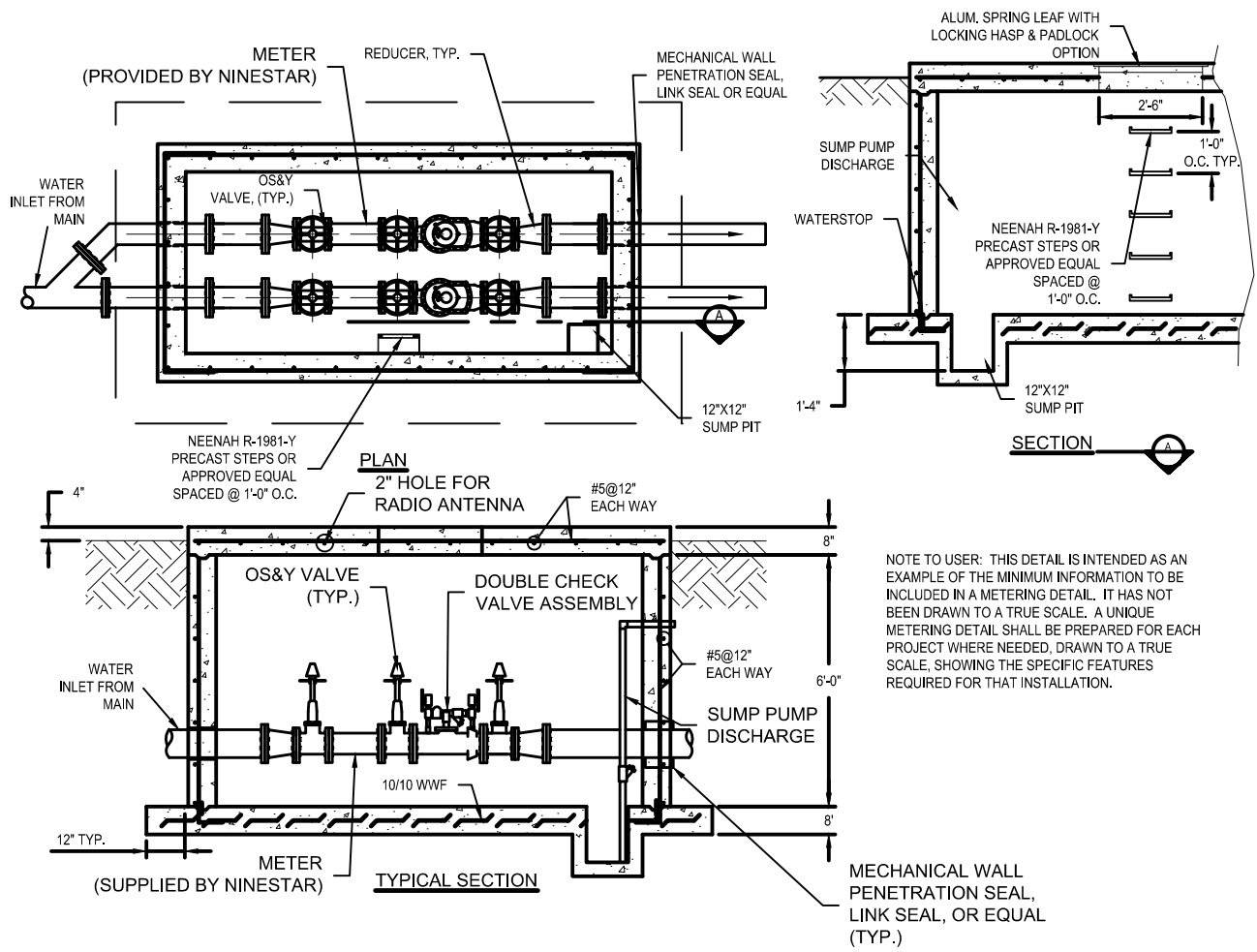

VAULT METERING DETAILS

DETAIL NO. 7J
DATE: 10/7/2025

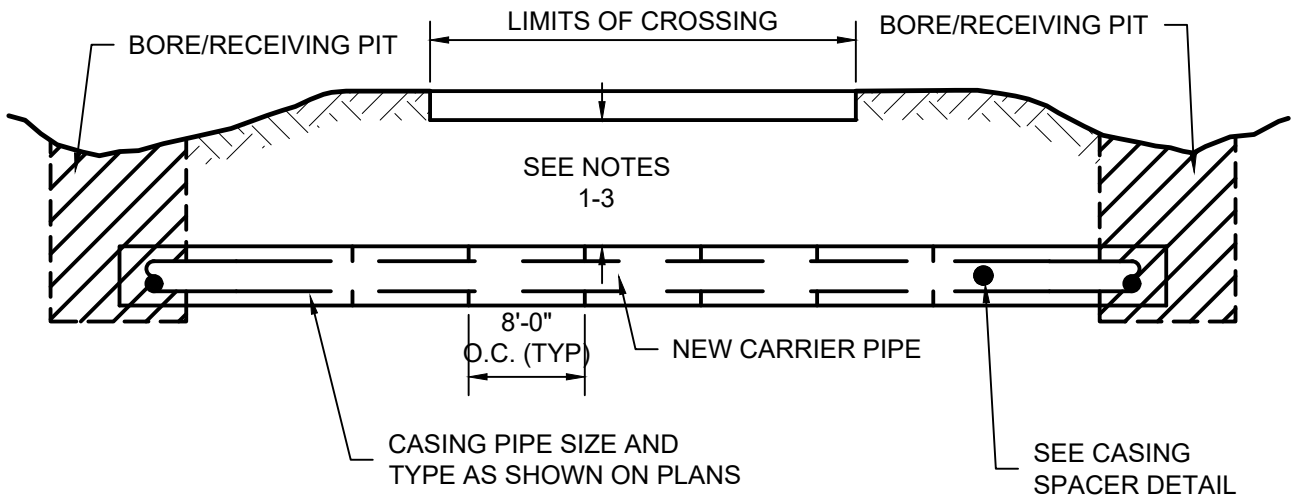

NOTES:

1. WATERWAY CROSSINGS: CASING PIPE SHALL BE AT LEAST 3'-0" BELOW WATERWAY BOTTOM.
2. HIGHWAY/ROADWAY CROSSINGS: CASING PIPE SHALL BE AT LEAST 4'-6" BELOW ROADWAY SUBBASE.
3. RAILROAD CROSSINGS: CASING PIPE SHALL BE DEPTH SPECIFIED BY RAILROAD AUTHORITY AND AS LISTED IN THE APPROVED PERMIT APPLICATION.



CASING PIPE

DETAIL NO. 7K
DATE: 9/11/2024

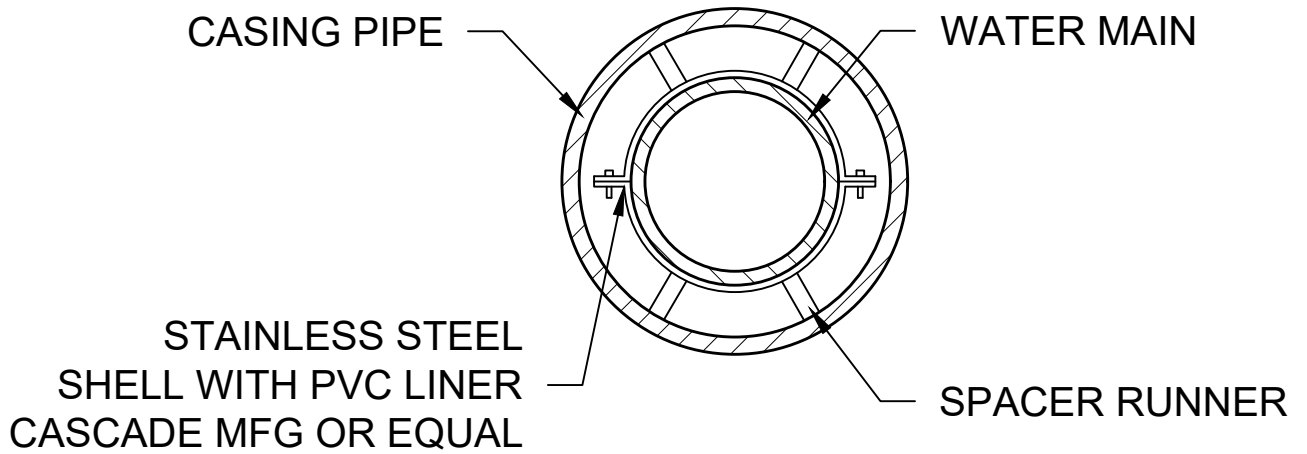

NOTES:

1. CASTING SPACERS TO BE THE CENTERED AND RESTRAINED TYPE.
2. INSTALL CASING SPACERS AT 8' INTERVALS.

Drawing: C:\Users\mason\OneDrive - Wessler Engineering\Incl\Desktop\NEW WINESTAR DETAILS (AUGUST 2024)\CASING SPACER.dwg | Layout: 8.5x11 Std | Plotted: 09/11/24 @ 12:20:33 | LastSavedBy: MasonF



CASING SPACER

DETAIL NO. 7L
DATE: 9/11/2024

Drawing: C:\Users\masonf\OneDrive - Wessler Engineering\Incl\Desktop\NEW WINESTAR DETAILS (AUGUST 2024)\WATERWAY CROSSING.dwg | Layout: 8.5x11 Std | Plotted: 09/11/24 @ 12:21:52 | LastSavedBy: MasonF

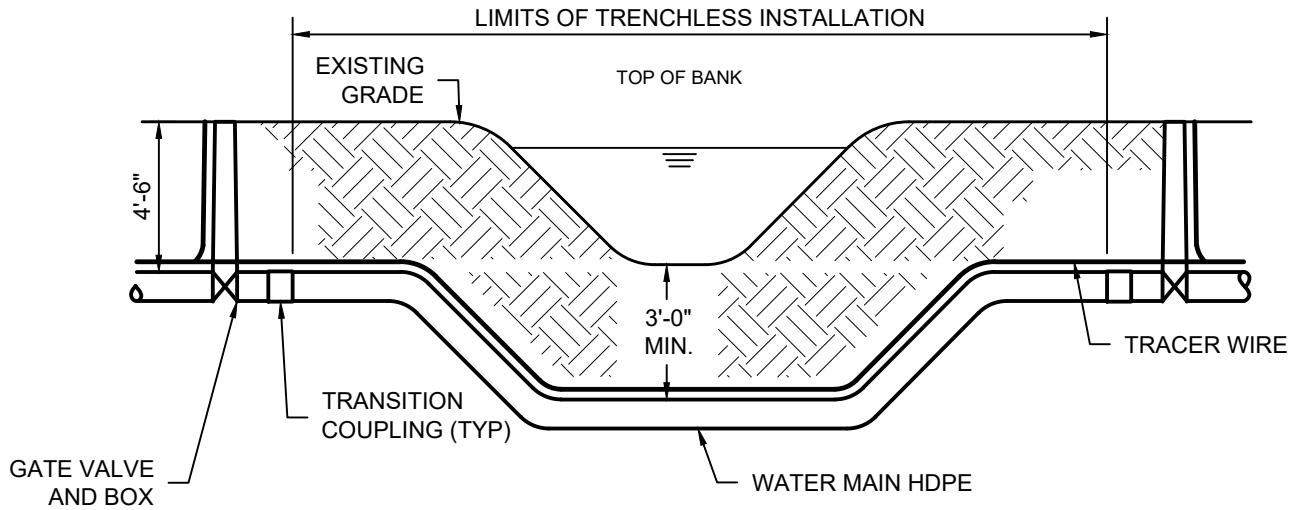

WATERWAY CROSSING

DETAIL NO. 7M
DATE: 9/11/2024

FEET OF RESTRAINED PIPE @ 150 PSI (A)

FITTING TYPE	WATER MAIN SIZE							
	4 INCH	6 INCH	8 INCH	10 INCH	12 INCH	14 INCH	16 INCH	18 INCH
11 1/4° BEND	1'	2'	2'	2'	2'	3'	3'	3'
22 1/2° BEND	2'	3'	3'	4'	4'	5'	5'	6'
45° BEND	3'	5'	6'	7'	8'	9'	10'	11'
90° BEND	8'	11'	13'	16'	19'	22'	24'	27'
11 1/4° VERTICAL BEND	2'	3'	4'	5'	6'	6'	7'	8'
22 1/2° VERTICAL BEND	4'	6'	8'	9'	11'	12'	14'	15'
45° VERTICAL BEND	9'	12'	15'	19'	22'	25'	28'	31'
VALVE/PLUG	20'	29'	37'	45'	52'	60'	67'	75'
TEE OUTLET	18'	27'	35'	48'	50'	58'	66'	73'
DEAD END	20'	29'	37'	45'	52'	60'	67'	75'

NOTE: TYPE 5 TRENCH, GOOD SAND OR GRAVEL BACKFILL

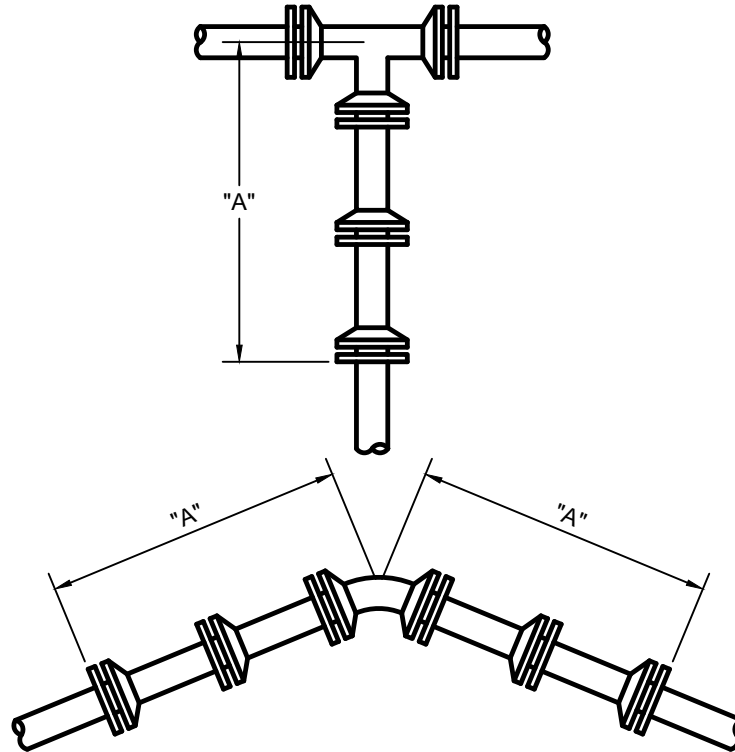

Drawing: C:\Users\mason\OneDrive - Wessler Engineering\Incl\Desktop\NEW\INESTAR DETAILS (AUGUST 2024)\WATER MAIN RESTRAINED PIPING.dwg | Layout: 8.5x11 Std | Plotted: 09/11/24 @ 12:24:54 | LastSavedBy: MasonF



WATER MAIN RESTRAINED PIPING

DETAIL NO. 7N
DATE: 9/11/2024

NOTES:

1. VALVE REQUIRED AT EACH CUL-DE-SAC. INSTALL VALVE TO AVOID CURBS & SIDEWALKS.
2. INSTALL HYDRANT WITHIN 150' OF THE BACK EDGE OF PAVEMENT OF CUL-DE-SAC.
3. INSTALL WATER MAINS ON OPPOSITE SIDE OF STREET FROM SANITARY SEWER.
4. ALL LIVE TAPS TO BE COMPLETED BY A CERTIFIED CONTRACTOR.

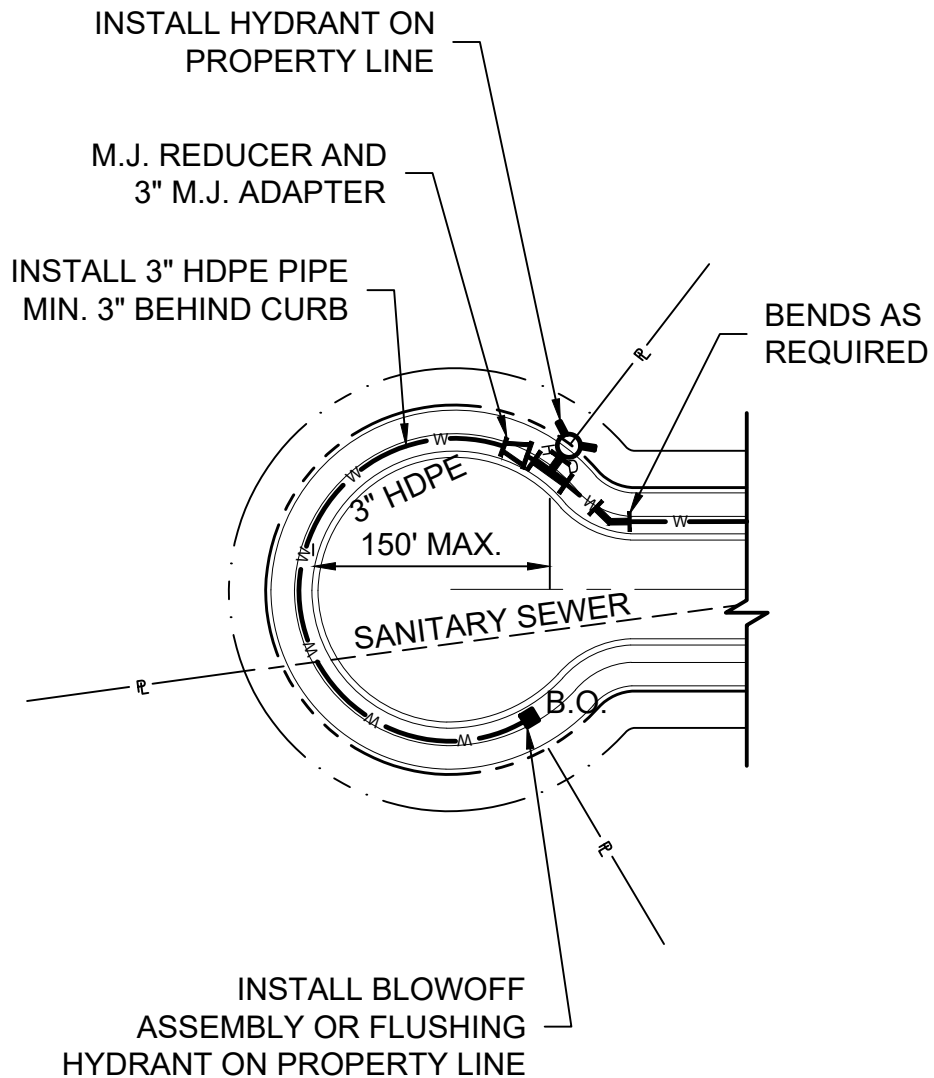

CUL-DE-SAC WATER MAIN & HYDRANT INSTALLATION

DETAIL NO. 70
DATE: 11/25/2024

FORMS

AFFIDAVIT AND RELEASE OF LIENS – CONTRACTOR

AFFIDAVIT AND RELEASE OF LIENS – SUBCONTRACTOR/SUPPLIER

FINAL COST FORM – WATER

FINAL COST FORM – SEWER

TRANSFER OF OWNERSHIP

CONTRACTOR
AFFIDAVIT AND RELEASE OF LIENS

WHEREAS, the undersigned contractor has installed or furnished labor, materials and/or equipment for the installation of potable water or sanitary sewer infrastructure and appurtenances in connection with a Project known as _____

(Project Name)

("Facilities"), pursuant to a written agreement dated _____, 20____, between the

_____, having an office at _____

(Owner)

(Address)

and the undersigned, having an office at _____, which Facilities are, or

(Address)

will be a part of the potable water or sanitary sewer system of Hancock Rural Telephone Corporation d/b/a/ NineStar Connect, Inc. and are located as follows:

WHEREAS, the undersigned is authorized and has agreed to release any and all claims and liens which it has against the Owner and the Facilities by reason of labor, materials or equipment furnished by it in connection with said installation;

NOW, THEREFORE, the undersigned, in consideration of the sum of One Dollar (\$1.00) and other valuable consideration, the receipt of which is hereby acknowledged, releases any and all liens, claims and demands which it now has, or might have in the future, against the Owner, its successors and assigns, on or against the Facilities, for work done or equipment or materials furnished in connection with the installation of the Facilities. It is the intent of this release that the Owner, its successors and assigns shall and may hold, use and enjoy the Facilities free and clear of all liens, claims and demands that may be asserted by the undersigned, its successors or assigns.

Executed this _____ day of _____, 20____.

(Name of Contractor)

Signed by: _____

Title: _____

STATE OF INDIANA
COUNTY OF _____

SS:

Before me, the undersigned, a Notary Public in and for said County and State, this _____ day of

_____ 20____, personally appeared _____, and acknowledged the execution of the foregoing Affidavit and Release of Liens.

WITNESS my name and official seal:

Notary Public

Printed Name

County of Residence

My Commission Expires: _____

SUBCONTRACTOR/SUPPLIER
AFFIDAVIT AND RELEASE OF LIENS

WHEREAS, the undersigned has installed or furnished labor, materials and/or equipment for the installation of potable water or sanitary sewer infrastructure and appurtenances in connection with a Project known as _____

(Project Name)

("Facilities"), pursuant to a written agreement dated _____, 20____, between the

_____, having an office at _____

(Owner)

(Address)

and the undersigned, having an office at _____, which

(Address)

Facilities are described and located as follows:

WHEREAS, the undersigned is authorized and has agreed to release any and all claims and liens which it has against the Owner and the Facilities by reason of labor, materials or equipment furnished by it in connection with said installation;

NOW, THEREFORE, the undersigned, in consideration of the sum of One Dollar (\$1.00) and other valuable consideration, the receipt of which is hereby acknowledged, releases any and all liens, claims and demands which it now has, or might have in the future, against the Owner, its successors and assigns, on or against the Facilities, for work done or equipment or materials furnished in connection with the installation of the Facilities. It is the intent of this release that the Owner, its successors and assigns shall and may hold, use and enjoy the Facilities free and clear of all liens, claims and demands that may be asserted by the undersigned, its successors or assigns. The undersigned further certifies and acknowledges, that it has received from the Contractor, payment in full on account of labor done and materials or equipment furnished to or in connection with the Facilities.

Executed this _____ day of _____, 20____.

(Name of Subcontractor/Supplier)

Signed by: _____

Title: _____

STATE OF INDIANA
COUNTY OF _____

SS:

Before me, the undersigned, a Notary Public in and for said County and State, this _____ day of

_____ 20____, personally appeared _____, and
acknowledged the execution of the foregoing Affidavit and Release of Liens.

WITNESS my name and official seal:

Notary Public

Printed Name

County of Residence

My Commission Expires: _____

**FINAL COST FORM
DEVELOPER INSTALLED WATER INFRASTRUCTURE**

PROJECT NAME & ADDRESS _____

PREPARED BY _____ DATE _____

Include materials, labor, equipment and all incidental costs for a complete installation in the unit cost. Fittings include tees, bends, couplings, sleeves, reducers, etc. and will be included in the Pipe costs.

ITEM DESCRIPTION	QUANTITY	PRICE/UNIT	UNIT	TYPE	COST
WATER INFRASTRUCTURE					
DI, C900 PVC, DR18 HDPE - INCLUDE PIPE, ALL FITTINGS, RESTRAINTS, BEDDING, BACKFILL, ETC.					
4-INCH		\$ -	FT		\$ -
6-INCH		\$ -	FT		\$ -
8-INCH		\$ -	FT		\$ -
12-INCH		\$ -	FT		\$ -
		\$ -	FT		\$ -
VALVES					
4-INCH GATE VALVE & BOX		\$ -	EA		\$ -
6-INCH GATE VALVE & BOX		\$ -	EA		\$ -
8-INCH GATE VALVE & BOX		\$ -	EA		\$ -
12-INCH GATE VALVE & BOX		\$ -	EA		\$ -
AIR RELEASE VALVE		\$ -	EA		\$ -
		\$ -	EA		\$ -
TAPPING SLEEVES & VALVES W/BOX					
4-INCH TAPPING SLEEVE, VALVE & BOX		\$ -	EA		\$ -
6-INCH TAPPING SLEEVE, VALVE & BOX		\$ -	EA		\$ -
8-INCH TAPPING SLEEVE, VALVE & BOX		\$ -	EA		\$ -
12-INCH TAPPING SLEEVE, VALVE & BOX		\$ -	EA		\$ -
		\$ -	EA		\$ -
FIRE HYDRANTS/BLOW OFFS					
5 1/4, 3 NOZZLE W/ VALVE & BOX		\$ -	EA		\$ -
BLOW OFF		\$ -	EA		\$ -
		\$ -	EA		\$ -
INCLUDE OTHER COSTS					
ENGINEERING DESIGN		\$ -	LS		\$ -
TESTING		\$ -	LS		\$ -
FINAL GRADING & SEEDING/ASPHALT		\$ -	LS		\$ -
EASEMENTS		\$ -	LS		\$ -
		\$ -			\$ -
TOTAL COST					\$ -

I hereby certify that this list of costs for water infrastructure for the above-named project is complete and accurate in accordance with the final pay application and invoices from the project contractor and engineer.

CERTIFIED BY: Signature of Developer _____

Title _____

Corporate Name _____

**FINAL COST FORM
DEVELOPER INSTALLED SANITARY SEWER INFRASTRUCTURE**

PROJECT NAME & ADDRESS _____

PREPARED BY _____ DATE _____

Include materials, labor, equipment and all incidental costs for a complete installation in the unit cost.
Include tees, bends, lateral cleanouts, granular backfill, in the Pipe costs.

ITEM DESCRIPTION	QUANTITY	PRICE/UNIT	UNIT	TYPE	COST
SANITARY SEWER INFRASTRUCTURE					
4-INCH LATERAL		\$ -	FT		\$ -
6-INCH LATERAL		\$ -	FT		\$ -
8-INCH GRAVITY		\$ -	FT		\$ -
10-INCH GRAVITY		\$ -	FT		\$ -
12-INCH GRAVITY		\$ -	FT		\$ -
3-INCH FORCE MAIN		\$ -	FT		\$ -
4-INCH FORCE MAIN		\$ -	FT		\$ -
6-INCH FORCE MAIN		\$ -	FT		\$ -
		\$ -	FT		\$ -
SANTARY MANHOLES					
4' DIA MANHOLE		\$ -	EA		\$ -
5' DIA MANHOLE		\$ -	EA		\$ -
6' DIA MANHOLE		\$ -	EA		\$ -
OTHER MANHOLE		\$ -	EA		\$ -
		\$ -	EA		\$ -
OTHER STRUCTURES					
AIR RELEASE VALVE/CLEANOUT		\$ -	EA		\$ -
		\$ -	EA		\$ -
PUMP STATIONS					
GRINDER PUMP STATION		\$ -	EA		\$ -
LIFT STATION, COMPLETE		\$ -	EA		\$ -
		\$ -	EA		\$ -
INCLUDE OTHER COSTS					
ENGINEERING DESIGN		\$ -	LS		\$ -
TESTING		\$ -	LS		\$ -
DRIVEWAY/STREET REPAIR		\$ -	LS		\$ -
FINAL GRADING & SEEDING		\$ -	LS		\$ -
EASEMENTS		\$ -	LS		\$ -
		\$ -			\$ -
TOTAL COST					\$ -

I hereby certify that this list of costs for sanitary infrastructure for the above-named project is complete and accurate in accordance with the final pay application and invoices from the project contractor and engineer.

CERTIFIED BY: Signature of Developer _____

Title _____

Corporate Name _____

TRANSFER OF OWNERSHIP
OF DEVELOPER INSTALLED (WATER MAINS/SANITARY SEWERS)

BY VIRTUE OF THIS DOCUMENT, THE UNDERSIGNED DOES SELL, CONVEY, CONVEYANT AND ASSIGN ALL RIGHTS AND OWNERSHIP OF (WATER MAINS/SANITARY SEWERS) AND APPURTENANCES INSTALLED AT:

(Project Name)

(Location)

As noted by the record drawings and per the materials on the "final cost form" which reflects a total cost for materials and installation of \$_____ to Hancock Rural Telephone Corporation d/b/a NineStar Connect (NineStar), together with a 3-year maintenance bond by the undersigned for the materials and workmanship for such (water mains/sanitary sewers) and appurtenances.

DEVELOPER'S CERTIFICATION

I certify that no advances or contributions for the construction of the (water mains/sanitary sewers) and appurtenances have been made by the Owners of any lots being served by these facilities, and there are no agreements which might result in claims that all or some part of the cost of the installed (water mains/sanitary sewers) and appurtenances has been contributed by any such person.

It is mutually understood and agreed that the undersigned warrants that goods and merchantable title to the (water mains/sanitary sewers) and appurtenances is vested in Developer, free and clear of all liens and or encumbrances. If any liens shall be filed or encumbrance asserted against the (water mains/sanitary sewers) and appurtenances, Developer, upon demand by NineStar shall cause the lien or encumbrance to be satisfied and released at Developer's expense.

The title to all facilities having been vested in NineStar all responsibility for repair and maintenance of such facilities shall be borne by NineStar, subject to a three-year maintenance bond, provided that any construction warranties received by this Developer in connection with the installation thereof shall automatically be assigned to NineStar (utility owning) for its benefit. Developer hereby assigns all construction warranties received in connection with the installation of the (water mains/sanitary sewers) and appurtenances to NineStar.

It is mutually understood and agreed that NineStar is a public utility and that its rights and obligations hereunder shall be subject to all applicable orders and rules and regulations of the Indiana Utility Regulatory Commission or other regulatory authorities as may have jurisdiction

and accordingly, applies to the operations, maintenance and ownership of these and all facilities described above.

(Corporate Seal Affixed) _____ (Developer's signature) _____ (Date) _____

STATE OF INDIANA SS:
COUNTY OF _____

Before me, the undersigned, a Notary Public in and for said County and State, this _____ day of _____ 20____, personally appeared _____ and acknowledged the execution of the foregoing Transfer of Ownership.

WITNESS my name and office seal:

Notary Public

Printed Name

My Commission Expires: _____

County of Residence